



PHÖNIX

STRACK

DAUME
REGELARMATUREN

SIP Solent & Pratt
Phönix Ltd

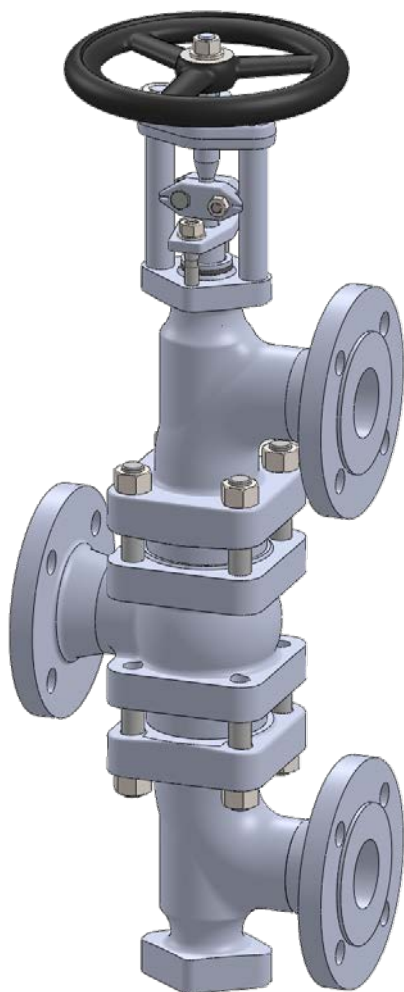

Change Over Valve Type 320 PN 40

Phönix Valve Group
Am Stadtbruch 6
34471 Volkmarsen

Phone:
web:
eMail:

+49 5693 988 0
www.phoenix-valvegroup.com
info@phoenix-valvegroup.com





Technical introduction

The Phönix change over valve is a three-way globe valve that is useful in all locations where a shutdown cannot be tolerated, either for safety reasons or due to plant and production conditions. With its globe valve style design the phönix valve offers advantages over conventional three-way ball or plug valves like bubble tight conical metal seating or an optional bellows stem seal. These and other features make the valve extremely useful for a wide range of applications.

Used as diverter valve (fig. 1) change over valves enable a quick and safe switch between product lines, safety systems, or to start-up tanks for solvent flushing. To accommodate different piping situations the Phönix Valve allows the rotation of the elbows to any 90° angle.

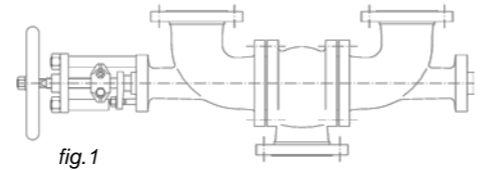

fig.1

Pressurized systems should always be equipped with dual safety relief devices to allow frequent maintenance without disabling the overpressure protection. In many cases safety relief valves are used and are subject to frequent resetting due to operating conditions. Phönix change over valves (fig. 2) offer the most convenient and ideal solution considering the short time of operation to switch between the safety relief valve in service and the standby valve. An important safety aspect is addressed due to the fact that the valve does not allow isolating both safety relief devices at the same time. Eliminating two full-bore shutoff valves as well as the reduction from two vessel/ system connections to one provides additional cost benefits.

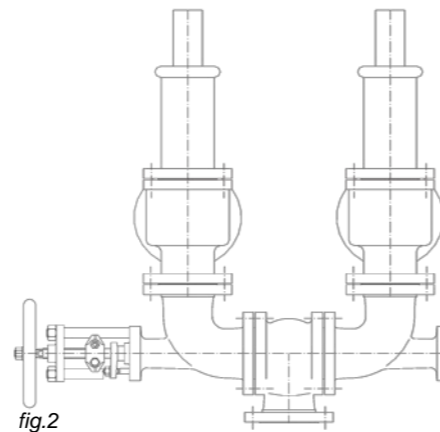

fig.2

The applicable standards, impositions, technical rules, and recommendations allow explicitly the use of change over valves when their design ensures that even during the switchover procedure the necessary free section for choke free flow is guaranteed. Phönix change over valves comply with this requirement. In addition the valves are designed for a high flow rate and minimal pressure drop.

For critical services involving toxic, aggressive or corrosive products that pose direct or indirect threats to people, plant, and environment the discharge into a closed collecting system might be required. For this purpose Phönix offers change over valve combinations to allow the mechanical link of two change over valves. One upstream and one downstream of the safety relief devices (fig. 3). The mechanical link allows operating both valves into the same direction and prevents involuntary isolation of the safety relief devices.

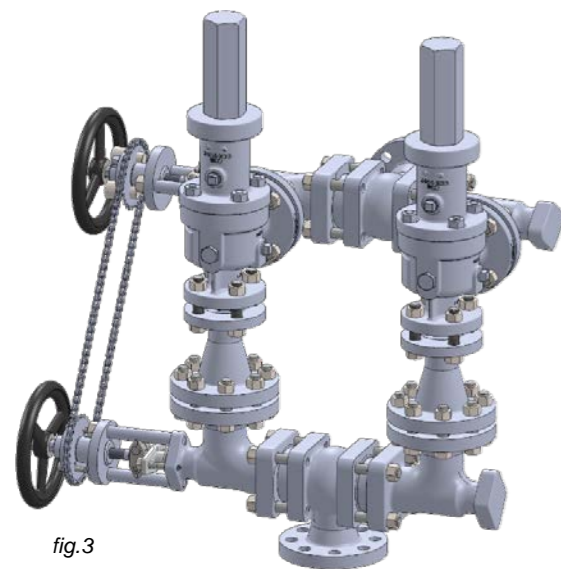

fig.3

Both the upstream and downstream change over valve must have identical dimensions in order to provide a synchronized controllable operation. Full lift safety relief valves have different inlet and outlet orifices. Therefore, pipe reducers must be placed between the upstream change over valve and the safety relief valves. This solution also allows for a very low pressure drop to the inlet of the safety relief valves and avoids expensive modifications of the change over valves.

To suit the nature of the process fluid, Phönix offers either bellows sealed or gland packed valves. Both options are part of the standard manufacturing program and can be equipped with manual, pneumatic, or electric operation. For fluids that tend to polymerize or crystallize the valves are available with optional heating jackets. For more information regarding design, standard materials, and options please refer to the product description of valve models 370 and 320.



Applications & design features

Applications

The 320 series is designed for dual relief valve systems to allow maintenance of the relief valves without the system being down, for reduction of vessel connections, for fast and easy operation, and for protection against involuntary isolation of both safety relief devices at the same time. For applications that require discharge into a collecting system model 320.1 provides a simple mechanism for the linkage of two change over valves for simultaneous operation.

Models 320 / 320.1 with a reliable, bubble tight shut-off can replace conventional three-way ball or plug valves. They are commonly used with non-hazardous media such as boiler and cooling water, saturated steam, and in similar systems as a bypass station to avoid shutdowns or as change over valve in combination with safety relief devices. Additionally, in polymer systems the change over valves are used to switch to start-up tanks for solvent flushing.

Design features

Body and bonnet

- split-body design allows for rotation of elbows to any 90° angle to accommodate different installation situation
- body bonnet joint gasket is fully confined to prevent gasket flow or blowout
- body parts are one-piece forgings or castings with larger than required wall thickness and integral flanges

Seats

- solid hardfacings for outstanding corrosion and wear resistance
- knife edge metal-to-metal seat for bubble-tight shutoff
- replaceable disc for inexpensive maintenance

Stem

- two-piece stem design eliminates stem bearings along with their maintenance needs
- cold-rolled and polished stem for reduced packing wear
- allows easy adaption for any type of actuation

= Zero emissions, zero seat leakage, low maintenance

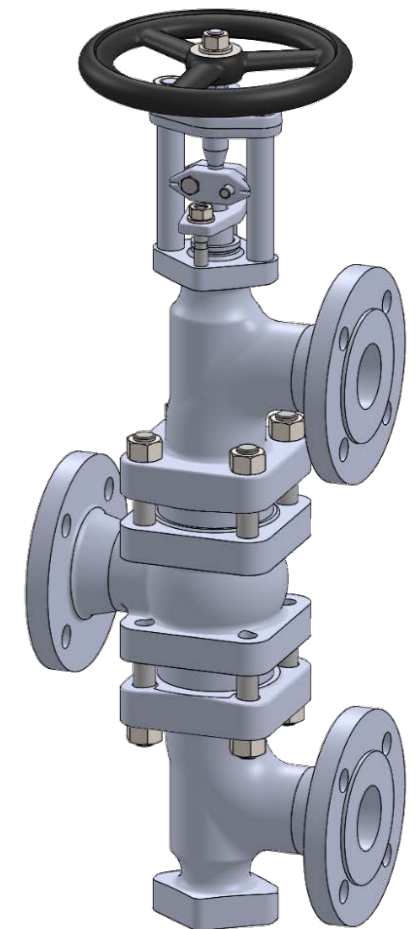



Standard Materials of Construction

Options

Other materials per customer requirements are available!

Notes

Phönix reserves the right to change product design and specification without notice!

Notes

- marking acc. to EN19, AD-A4, PED 2014/68/EU, CE
- standard tests acc. to DIN EN12266, ISO 5208
- preservation acc. to manufacturer standard
- connections: flanges acc. to DIN EN1092-1
butt weld ends acc. to DIN EN12627
socket weld ends acc. to DIN EN12760
- F-t-F dimensions: manufacturer standard

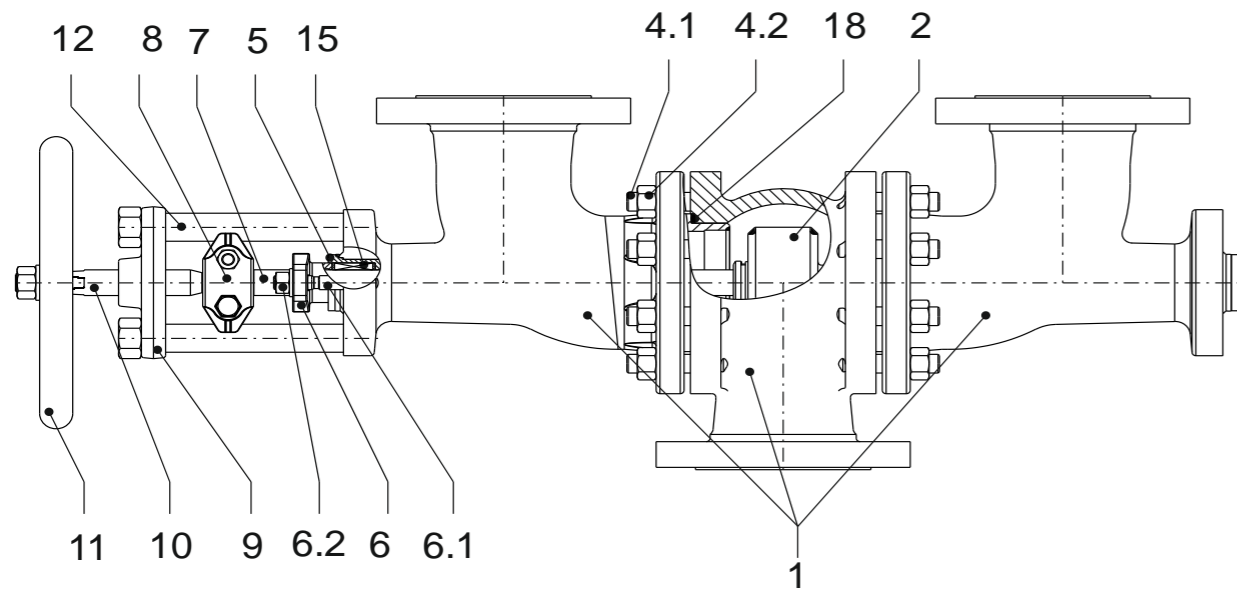

Materials

Item	Part Name	Carbon steel Model 320C up to 450°C	low temp. Carbon steel Model 320T -50°C up to 300°C	Stainless steel Model 320V -200°C up to 400°C
1	Body	1.0460 / 1.0619	1.0566 / 1.1138	1.4404 / 1.4408
	Seat overlay	1.4370 (≈ 200HRB)	1.4370 (≈ 200HRB)	like body (≈ 200HRB)
2	Disc	1.4021 hardened / 1.0460	1.4571 / 1.0566	1.4571
	Overlay	1.4009 (≈ 300HRB)	Stellite 6 (≈ 42HRC)	Stellite 6 (≈ 42HRC)
4.1	Stud bolt	1.7709	A4-70	A4-70
4.2	Hex. nut	1.7218	A4-70	A4-70
5	Stuffing box body	1.4571	1.4571	1.4571
6	Gland follower	1.0619	1.5638	1.4408
6.1	Stud bolt	Steel 5.6	A4-70	A4-70
6.2	Hex. nut	Steel 5	A4-70	A4-70
7	Lower stem	1.4571	1.4571	1.4571
8	Coupling	1.4408	1.4408	1.4408
9	Bridge	1.0460, QPQ-nitrided	1.0460, QPQ-nitrided	1.0460, QPQ-nitrided
10	Upper stem	1.4057	1.4057	1.4057
11	Handwheel	Cast iron	Cast iron	Cast iron
12	Pillar	1.0501	1.4057	1.4057
15	Packing	Graphite	PTFE-silk *	Graphite
18	Gasket	Grooved SS / graphite	Grooved SS / graphite	Grooved SS / graphite

* ≥220°C Packing of pure graphite

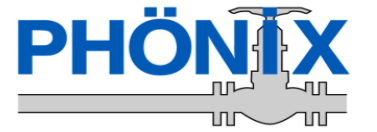

PN40 Sizes DN15 - DN500

Options

- Other customer specific designs on request

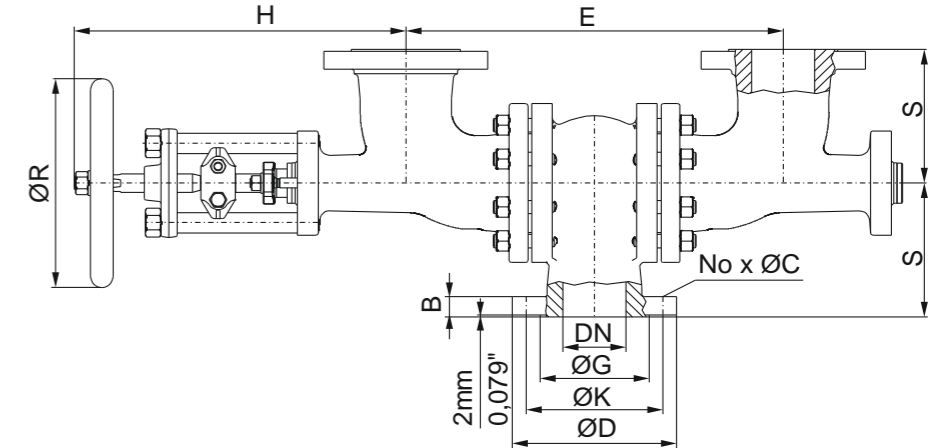

Dimensions & Weights & Flow Coefficients

DN	Unit	E	S	H	H	ØR	ØG	ØK	No x ØC	ØD	B	Weight 320	Weight 320.1	Kv [m³/h] cv [USGal/min]	ζ [-]
15	[mm] [in]	245 9.65	100 3.94	260 10.24	305 12.01	150 5.91	45 1.77	65 2.56	4 x 14 4 x 0.55	95 3.74	16 0.63	16 kg 35 lbs	20 kg 44 lbs	5.3 6.16	2.8
20	[mm] [in]	245 9.65	100 3.94	260 10.24	305 12.01	150 5.91	58 2.28	75 2.95	4 x 14 4 x 0.55	105 4.13	18 0.71	16 kg 35 lbs	20 kg 44 lbs	12 13.95	1.9
25	[mm] [in]	245 9.65	100 3.94	260 10.24	305 12.01	150 5.91	68 2.68	85 3.35	4 x 14 4 x 0.55	115 4.53	18 0.71	16 kg 35 lbs	20 kg 44 lbs	17 19.77	2.1
32	[mm] [in]	353 13.90	120 4.72	285 11.22	320 12.60	200 7.87	78 3.07	100 3.94	4 x 18 4 x 0.71	140 5.51	18 0.71	20 kg 44 lbs	24 kg 53 lbs	29.3 34	1.95
40	[mm] [in]	353 13.90	120 4.72	285 11.22	320 12.60	200 7.87	88 3.46	110 4.33	4 x 18 4 x 0.71	150 5.91	18 0.71	26 kg 57 lbs	30 kg 66 lbs	45.6 53	1.95
50	[mm] [in]	353 13.90	120 4.72	285 11.22	320 12.60	200 7.87	102 4.02	125 4.92	4 x 18 4 x 0.71	165 6.50	20 0.79	32 kg 71 lbs	39 kg 86 lbs	69 80	1.9
65	[mm] [in]	400 15.75	135 5.31	395 15.55	400 15.75	250 9.84	122 4.80	145 5.71	8 x 18 8 x 0.71	185 7.28	22 0.87	44 kg 97 lbs	56 kg 123 lbs	120 140	2
80	[mm] [in]	440 17.32	160 6.30	405 15.94	415 16.34	250 9.84	138 5.43	160 6.30	8 x 18 8 x 0.71	200 7.87	24 0.94	67 kg 148 lbs	83 kg 183 lbs	177 206	2.1
100	[mm] [in]	508 20.00	180 7.09	490 19.29	505 19.88	315 12.40	162 6.38	190 7.48	8 x 22 8 x 0.87	235 9.25	24 0.94	88 kg 194 lbs	110 kg 243 lbs	273 317	2.15
125	[mm] [in]	600 23.62	200 7.87	490 19.29	505 19.88	315 12.40	188 7.40	220 8.66	8 x 26 8 x 1.02	270 10.63	26 1.02	125 kg 276 lbs	151 kg 333 lbs	421 490	2.2
150	[mm] [in]	670 26.38	220 8.66	630 24.80	665 26.18	400 15.75	218 8.58	250 9.84	8 x 26 8 x 1.02	300 11.81	28 1.10	159 kg 351 lbs	192 kg 423 lbs	644 749	1.8
200	[mm] [in]	820 32.28	240 9.45	680 26.77	745 29.33	500 19.69	285 11.22	320 12.60	12 x 30 12 x 1.18	375 14.76	34 1.34	235 kg 518 lbs	285 kg 628 lbs	1044 1214	2.35
250	[mm] [in]	1000 39.37	310 12.20	780 30.71	745 29.33	500 19.69	345 13.58	385 15.16	12 x 33 12 x 1.30	450 17.72	38 1.50	437 kg 963 lbs	487 kg 1074 lbs	1398 1626	3.2
300	[mm] [in]	1050 41.34	330 12.99	825 32.48	900 35.43	630 24.80	410 16.14	450 17.72	16 x 33 16 x 1.30	515 20.28	42 1.65	681 kg 1501 lbs	741 kg 1634 lbs	1872 2177	3.7
350	[mm] [in]	1320 51.97	400 15.75	1010 39.76	1065 41.93	630 24.80	465 18.31	510 20.08	16 x 36 16 x 1.42	580 22.83	46 1.81	1078 kg 2377 lbs	1148 kg 2531 lbs	2547 2962	3.7
400	[mm] [in]	1520 59.84	400 15.75	1050 41.34	1100 43.31	720 28.35	535 21.06	585 23.03	16 x 39 16 x 1.54	660 25.98	50 1.97	1559 kg 3437 lbs	1639 kg 3613 lbs	3200 3721	4
500	[mm] [in]	1800 70.87	550 21.65	1250 49.21	1270 50.00	720 28.35	615 24.21	670 26.38	20 x 42 20 x 1.65	755 29.72	57 2.24	1877 kg 4138 lbs	1957 kg 4314 lbs	5000 5814	4

- other sizes on request

Contact us

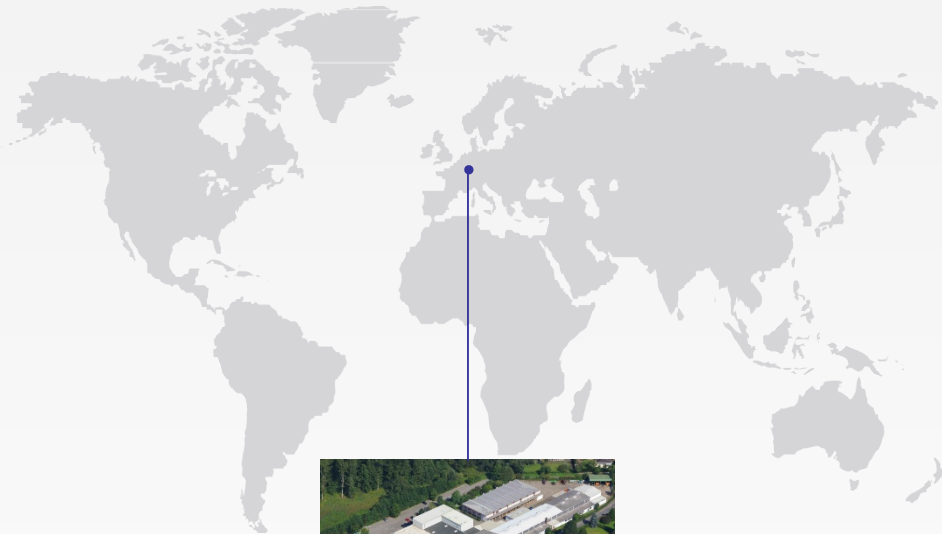

Volkmarsen, Germany

Sales and Operations

Phönix Valve Group GmbH

Volkmarsen, Germany
Phone: +49 5693 988 0
Email: info@phoenix-valvegroup.com
Website: www.phoenix-valvegroup.com

Phönix Armaturen Werke-Bregel GmbH

Volkmarsen, Germany
Phone: +49 5693 988 0
Email: info@phoenix-valvegroup.com
Website: www.phoenix-valvegroup.com

Strack GmbH

Volkmarsen, Germany
Phone: +49 5693 988 0
Email: info@phoenix-valvegroup.com
Website: www.phoenix-valvegroup.com

PAW SARL

Genay Cedex, France
Phone: +33 437 408 195
Email: commercial@phoenix-valvegroup.com
Website: www.phoenix-valvegroup.com

Daume Regelarmaturen GmbH

Volkmarsen, Germany
Phone: +49 5693 988 0
Email: info@phoenix-valvegroup.com
Website: www.phoenix-valvegroup.com

Solent & Pratt Phönix Ltd.

Volkmarsen, Germany
Phone: +49 5693 988 0
Email: info@phoenix-valvegroup.com
Website: www.phoenix-valvegroup.com



While this information is presented in good faith and believed to be accurate, Phönix Valve Group GmbH, does not guarantee satisfactory results from reliance on such information. Nothing contained herein is to be construed as a warranty or guarantee, expressed or implied, regarding the performance, merchantability, fitness or any other matter with respect to the products, nor as a recommendation to use any product or process in conflict with any patent. Phönix Valve Group GmbH, reserves the right, without notice, to alter or improve the designs or specifications of the products described herein.

© 2022 Phönix Valve Group. All rights reserved. Specifications are subject to change without notice. All trademarks are property of their respective owners

Printed in Germany
09/22-R0