



PHÖNIX

STRACK

DAUME
REGELARMATUREN



Solent & Pratt
Phoenix Ltd

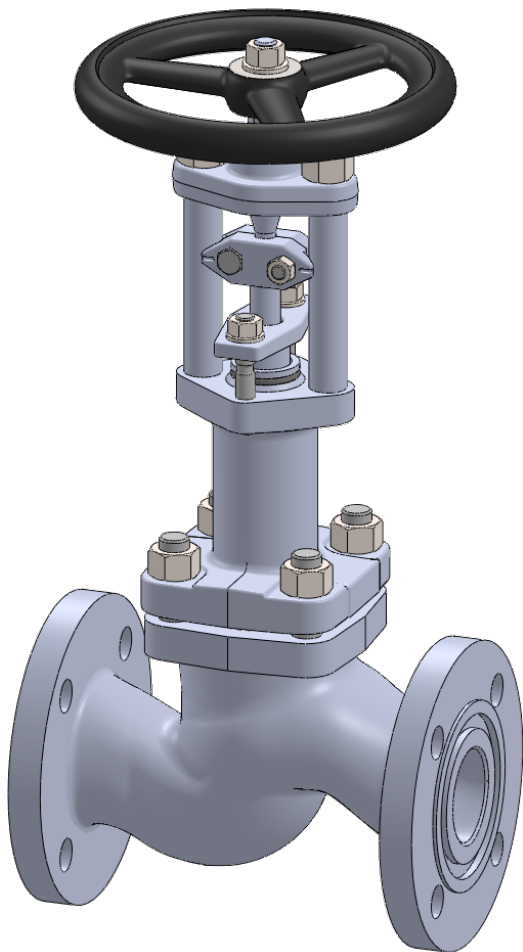

Stop Check Valve

Type 346

PN 16

Phönix Valve Group
Am Stadtbruch 6
34471 Volkmarsen

Phone:
web:
eMail:

+49 5693 988 0
www.phoenix-valvegroup.com
info@phoenix-valvegroup.com





Model 346

Straight Way / Protected Bellows

Applications & Design Features

Applications

Model 346 is designed for critical service applications involving lethal, toxic, corrosive, inflammable, volatile, radiating, or expensive fluids.

The most common applications are

- Dry Chlorine (Cl₂)
- Anhydrous Hydrogen Chloride (HCl)
- Vinyl Chloride Monomer (VCM)
- Ethylene Dichloride (EDC)
- Anhydrous Hydrofluoric Acid (HF)
- Isocyanites (MDI, TDI, HDI, etc.)
- heat transfer fluid application (steam, hot oil, molten Sodium, etc.) and
- fluids of similar nature.

The unique valve design guarantees reliable and excellent protection against leaks or fugitive emissions as well as excellent protection against back streaming in a pipeline. It is an ideal back stop. The spring loaded option allows any installation position. The stem seal requires virtually no maintenance due to leak free weld connections of the bellows with bonnet and stem. Constant packing monitoring and re-packing is eliminated. In the unlikely event of a bellows failure the backup packing guarantees safe valve performance until the next scheduled shutdown.

Design Features

Bellows and Packing

- bellows protected in extended bonnet against direct impingement from product flow
- multiple walls and hydroformed bellows
- up to 50.000 bellows operations guaranteed

Stem

- two-piece stem protects the bellows against torque stress
- design eliminates stem bearings along with their maintenance needs
- guided stem on top and bottom
- one-piece stem design upon request

Body and Bonnet

- bodies are forgings or castings with larger than required wall thickness and integral flanges
- extended bonnet provides for good thermal insulation
- body bonnet joint gasket is fully confined to prevent gasket flow or blowout

Seats

- solid hardfacings for outstanding corrosion and wear resistance
- replaceable disc for inexpensive maintenance

= zero emissions, zero seat leakage, low maintenance

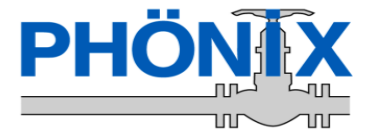
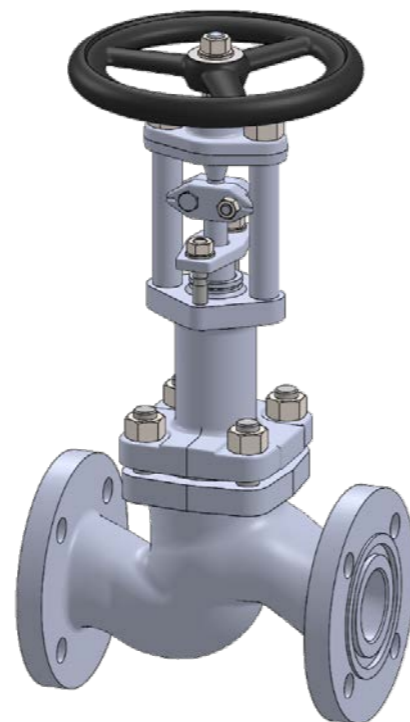

Model 346

Straight Way / Protected Bellows

Standard Materials of Construction

Options

Other materials per customer requirements are available!

Notes

Phönix reserves the right to change product design and specification without notice!

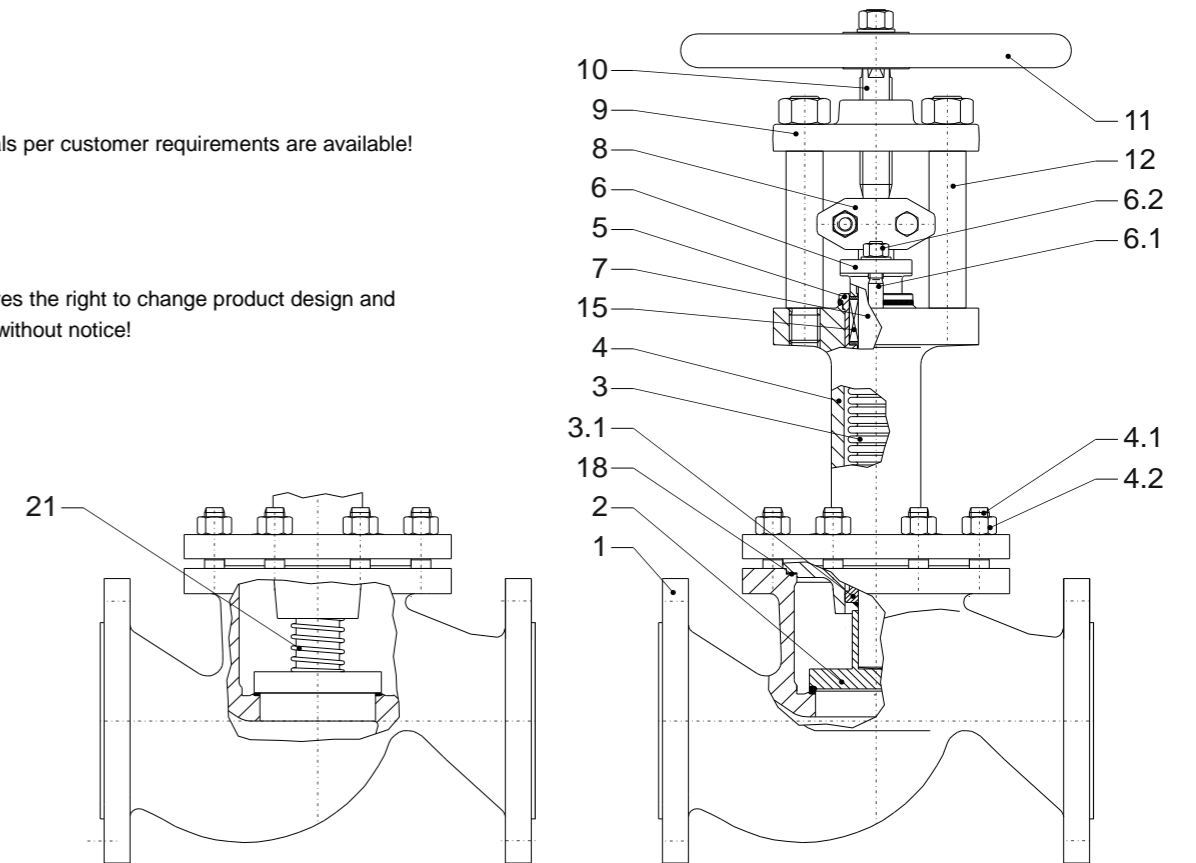

Materials

Item	Part Name	Carbon steel Model 350C up to 450°C	Stainless steel Model 350V -200°C up to 400°C
1	Body	1.0460 / 1.0619	1.4404 / 1.4408
	Seat overlay	1.4370 (≈ 200HRB)	like body (≈ 200HRB)
2	Disc	1.4021 hardened / 1.0460	1.4571
	Overlay	1.4009 (≈ 300HRB)	Stellite 6 (≈ 42HRC)
3	Bellows	1.4571	1.4571
3.1	Guide ring	1.4571	1.4571
4	Bonnet	1.0460 / 1.0619	1.4404 / 1.4408
4.1	Stud bolt	1.7709	A4-70
4.2	Hex. nut	1.7218	A4-70
5	Stuffing box body	1.4571	1.4571
6	Gland follower	1.0619	1.4408
6.1	Stud bolt	Steel 5.6	A4-70
6.2	Hex. nut	Steel 5	A4-70
7	Lower stem	1.4571	1.4571
8	Coupling	1.4408	1.4408
9	Bridge	1.0460, QPQ-nitrided	1.0460, QPQ-nitrided
10	Upper stem	1.4057	1.4057
11	Handwheel	Cast iron	Cast iron
12	Pillar	1.0501	1.4057
15	Packing	Graphite	Graphite
18	Gasket	Grooved SS / graphite	Grooved SS / graphite
21	Pressure spring **	1.4571	1.4571

** OPTIONAL



Model 346

Straight Way / Protected Bellows

PN16 Sizes DN15 - DN150

Options

- Other customer specific designs on request

Notes

- Design acc. PED 2014/68/EU and harmonized standards
- Marking acc. to EN 19, AD-A4, PED 2014/68/EU, CE
- Standard tests acc. to DIN EN 12266, ISO 5208
- Preservation acc. to manufacturer standard
- Connections:
 - Flanges acc. to DIN EN 1092-1
 - Butt Weld Ends acc. to DIN EN 12627
 - Socket Weld Ends acc. to DIN EN 12760
- F-T-F Dimensions:
 - Flanges acc. to DIN EN 558-1
 - Butt Weld Ends acc. to DIN EN 12982
 - Socket Weld Ends acc. to manufacturer standard

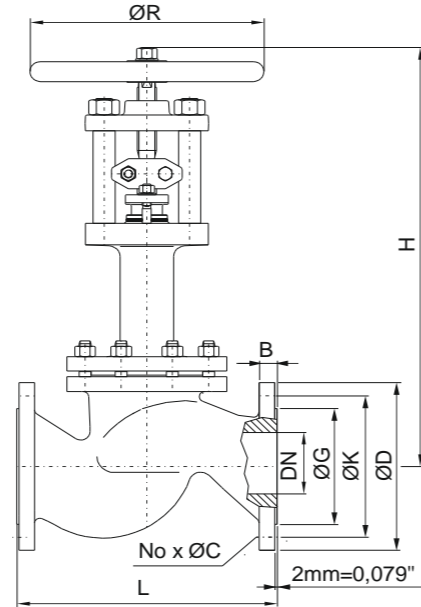

Dimensions & Weights & Flow Coefficients

DN	Unit	Globe		Flange facing type B1						Kv [m³/h]	
		L	H	ØR	ØG	ØK	No x ØC	ØD	B	Weight	cv [USGal/min]
15	[mm]	130	355	150	45	65	4 x 14	95	16	6.5 kg	3.4
	[in]	5.12	13.98	5.91	1.77	2.56	4 x 0.55	3.74	0.63	14.3 lbs	3.95
20	[mm]	150	345	150	58	75	4 x 14	105	18	7 kg	7
	[in]	5.91	13.58	5.91	2.28	2.95	4 x 0.55	4.13	0.71	15.4 lbs	8.14
25	[mm]	160	365	150	68	85	4 x 14	115	18	8 kg	9.5
	[in]	6.30	14.37	5.91	2.68	3.35	4 x 0.55	4.53	0.71	17.6 lbs	11.05
32	[mm]	180	405	200	78	100	4 x 18	140	18	14 kg	18
	[in]	7.09	15.94	7.87	3.07	3.94	4 x 0.71	5.51	0.71	31 lbs	20.93
40	[mm]	200	420	200	88	110	4 x 18	150	18	16 kg	27
	[in]	7.87	16.54	7.87	3.46	4.33	4 x 0.71	5.91	0.71	35 lbs	31
50	[mm]	230	420	200	102	125	4 x 18	165	18	19 kg	40
	[in]	9.06	16.54	7.87	4.02	4.92	4 x 0.71	6.50	0.71	42 lbs	47
65	[mm]	290	425	200	122	145	8 x 18	185	18	29 kg	78
	[in]	11.42	16.73	7.87	4.80	5.71	8 x 0.71	7.28	0.71	64 lbs	91
80	[mm]	310	520	250	138	160	8 x 18	200	20	38 kg	113
	[in]	12.20	20.47	9.84	5.43	6.30	8 x 0.71	7.87	0.79	84 lbs	131
100	[mm]	350	625	315	158	180	8 x 18	220	20	60 kg	179
	[in]	13.78	24.61	12.40	6.22	7.09	8 x 0.71	8.66	0.79	132 lbs	208
125	[mm]	400	625	315	188	210	8 x 18	250	22	95 kg	256
	[in]	15.75	24.61	12.40	7.40	8.27	8 x 0.71	9.84	0.87	209 lbs	298
150	[mm]	480	840	400	212	240	8 x 22	285	22	125 kg	405
	[in]	18.90	33.07	15.75	8.35	9.45	8 x 0.87	11.22	0.87	276 lbs	471

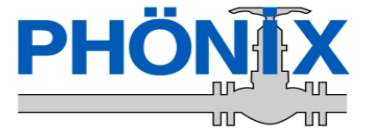

Model 346

Straight Way / Protected Bellows

PN16 Sizes DN15 - DN150

Options

- Other customer specific designs on request

Notes

- Design acc. PED 2014/68/EU and harmonized standards
- Marking acc. to EN 19, AD-A4, PED 2014/68/EU, CE
- Standard tests acc. to DIN EN 12266, ISO 5208
- Preservation acc. to manufacturer standard
- Connections:
 - Flanges acc. to DIN EN 1092-1
 - Butt Weld Ends acc. to DIN EN 12627
 - Socket Weld Ends acc. to DIN EN 12760
- F-T-F Dimensions:
 - Flanges acc. to DIN EN 558-1
 - Butt Weld Ends acc. to DIN EN 12982
 - Socket Weld Ends acc. to manufacturer standard

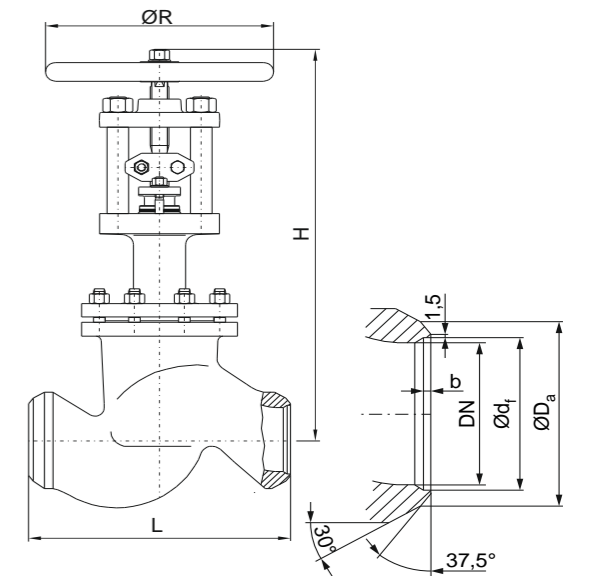

Dimensions & Weights & Flow Coefficients

DN	Unit	Globe		ØR	Butt Weld Ends			Weight	Kv [m³/h]	
		L	H		ØD _a	Ød _f	b		for pipe	cv [USGal/min]
15	[mm]	130	380	150	22	17	3	Ø21.3 x 2.0	5.1 kg	3.4
	[in]	5.12	14.96	5.91	0.87	0.67	0.12	Ø0.84 x 0.08	11.2 lbs	3.95
20	[mm]	150	380	150	28	22	4	Ø26.9 x 2.3	6.1 kg	7
	[in]	5.91	14.96	5.91	1.10	0.87	0.16	Ø1.06 x 0.09	13.4 lbs	8.14
25	[mm]	160	380	150	35	28.5	4	Ø33.7 x 2.6	5.7 kg	9.5
	[in]	6.30	14.96	5.91	1.38	1.12	0.16	Ø1.33 x 0.10	12.6 lbs	11.05
32	[mm]	180	430	200	44	ON REQUEST			10.6 kg	18
	[in]	7.09	16.93	7.87	1.73				23 lbs	20.93
40	[mm]	200	430	200	50	43	4	Ø48.3 x 2.6	12.2 kg	27
	[in]	7.87	16.93	7.87	1.97	1.69	0.16	Ø1.90 x 0.10	27 lbs	31
50	[mm]	230	440	200	62	53.5	5	Ø60.3 x 3.2	14 kg	40
	[in]	9.06	17.32	7.87	2.44	2.11	0.20	Ø2.37 x 0.13	31 lbs	47
65	[mm]	290	425	200	77	68.5	6	Ø76.1 x 3.6	23 kg	78
	[in]	11.42	16.73	7.87	3.03	2.70	0.24	Ø3.00 x 0.14	51 lbs	91
80	[mm]	310	480	250	91	80.5	6	Ø88.9 x 4.0	31 kg	113
	[in]	12.20	18.90	9.84	3.58	3.17	0.24	Ø3.50 x 0.16	68 lbs	131
100	[mm]	350	565	315	117	104.3	8	Ø114.3 x 5.0	50 kg	179
	[in]	13.78	22.24	12.40	4.61	4.11	0.31	Ø4.50 x 0.20	110 lbs	208
125	[mm]	400	625	315	144	130.5	7	Ø139.7 x 4.5	83 kg	256
	[in]	15.75	24.61	12.40	5.67	5.14	0.28	Ø5.50 x 0.18	183 lbs	298
150	[mm]	480	840	400	172	157	9	Ø168.3 x 5.6	108 kg	405
	[in]	18.90	33.07	15.75	6.77	6.18	0.35	Ø6.63 x 0.22	238 lbs	471

Contact us

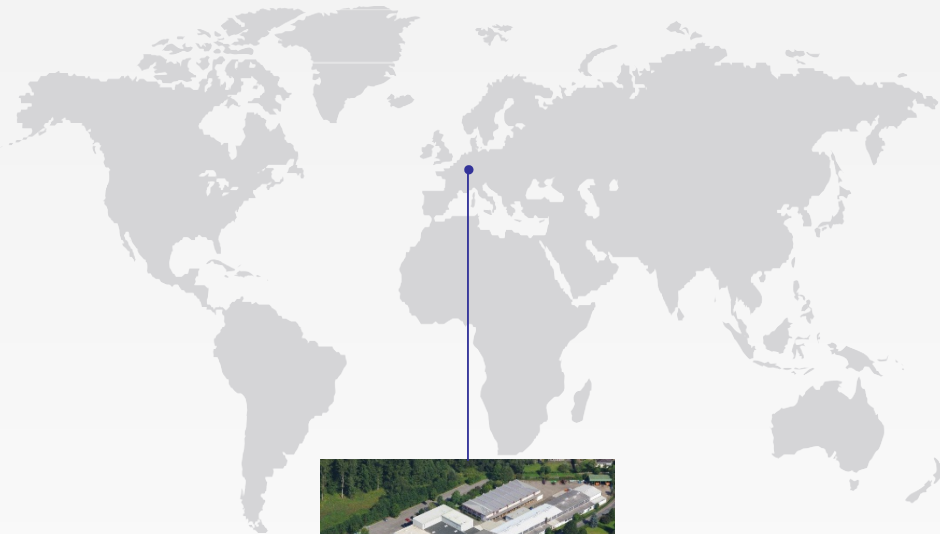

Volkmarsen, Germany

Sales and Operations

Phönix Valve Group GmbH

Volkmarsen, Germany
Phone: +49 5693 988 0
Email: info@phoenix-valvegroup.com
Website: www.phoenix-valvegroup.com

Phönix Armaturen Werke-Bregel GmbH

Volkmarsen, Germany
Phone: +49 5693 988 0
Email: info@phoenix-valvegroup.com
Website: www.phoenix-valvegroup.com

Strack GmbH

Volkmarsen, Germany
Phone: +49 5693 988 0
Email: info@phoenix-valvegroup.com
Website: www.phoenix-valvegroup.com

PAW SARL

Genay Cedex, France
Phone: +33 437 408 195
Email: commercial@phoenix-valvegroup.com
Website: www.phoenix-valvegroup.com

Daume Regelarmaturen GmbH

Volkmarsen, Germany
Phone: +49 5693 988 0
Email: info@phoenix-valvegroup.com
Website: www.phoenix-valvegroup.com

Solent & Pratt Phönix Ltd.

Volkmarsen, Germany
Phone: +49 5693 988 0
Email: info@phoenix-valvegroup.com
Website: www.phoenix-valvegroup.com



While this information is presented in good faith and believed to be accurate, Phönix Valve Group GmbH, does not guarantee satisfactory results from reliance on such information. Nothing contained herein is to be construed as a warranty or guarantee, expressed or implied, regarding the performance, merchantability, fitness or any other matter with respect to the products, nor as a recommendation to use any product or process in conflict with any patent. Phönix Valve Group GmbH, reserves the right, without notice, to alter or improve the designs or specifications of the products described herein.

© 2022 Phönix Valve Group. All rights reserved. Specifications are subject to change without notice. All trademarks are property of their respective owners

Printed in Germany
09/22-R0