



PHÖNIX

STRACK

DAUME
REGELARMATUREN

SIP Solent & Pratt
Phönix Ltd

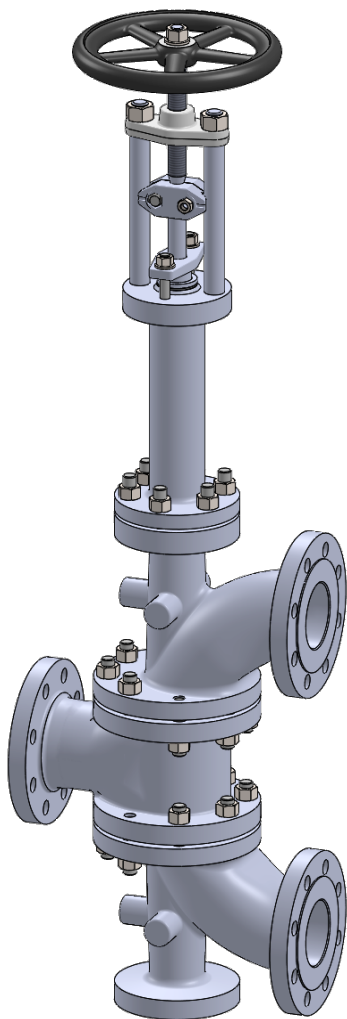

Change Over Valve Type 370B PN 40

Phönix Valve Group
Am Stadtbruch 6
34471 Volkmarsen

Phone:
web:
eMail:

+49 5693 988 0
www.phoenix-valvegroup.com
info@phoenix-valvegroup.com





Technical introduction

The Phönix Change Over Valve is a three-way globe valve that is useful in all locations where a shutdown cannot be tolerated, either for safety reasons or due to plant and production conditions. With its globe valve style design the Phönix valve offers advantages over conventional three-way ball or plug valves like bubble tight conical metal seating or an optional bellows stem seal. These and other features make the valve extremely useful for a wide range of applications.

Used as diverter valve (fig. 1) Change Over Valves enable a quick and safe switch between product lines, safety systems, or to start-up tanks for solvent flushing. To accommodate different piping situations the Phönix Valve allows the rotation of the elbows to any 90° angle.

Pressurized systems should always be equipped with dual safety relief devices to allow frequent maintenance without disabling the overpressure protection. In many cases safety relief valves are used and are subject to frequent resetting due to operating conditions. Phönix Change Over Valves (fig. 2) offer the most convenient and ideal solution considering the short time of operation to switch between the safety relief valve in service and the standby valve. An important safety aspect is addressed due to the fact that the valve does not allow isolating both safety relief devices at the same time. Eliminating two full-bore shutoff valves as well as the reduction from two vessel/system connections to one provides additional cost benefits.

The applicable standards, impositions, technical rules, and recommendations allow explicitly the use of Change Over Valves when their design ensures that even during the switchover procedure the necessary free section for choke free flow is guaranteed. Phönix Change Over Valves comply with this requirement. In addition the valves are designed for a high flow rate and minimal pressure drop.

For critical services involving toxic, aggressive or corrosive products that pose direct or indirect threats to people, plant, and environment the discharge into a closed collecting system might be required. For this purpose Phönix offers Change Over Valve combinations to allow the mechanical link of two Change Over Valves. One upstream and one downstream of the safety relief devices (fig. 3). The mechanical link allows operating both valves into the same direction and prevents involuntary isolation of the safety relief devices.

Both the upstream and downstream Change Over Valve must have identical dimensions in order to provide a synchronized controllable operation. Full lift safety relief valves have different inlet and outlet orifices. Therefore, pipe reducers must be placed between the upstream Change Over Valve and the safety relief valves. This solution also allows for a very low pressure drop to the inlet of the safety relief valves and avoids expensive modifications of the Change Over Valves.

To suit the nature of the process fluid, Phönix offers either bellows sealed or gland packed valves. Both options are part of the standard manufacturing program and can be equipped with manual, pneumatic, or electric operation. For fluids that tend to polymerize or crystallize the valves are available with optional heating jackets. For more information regarding design, standard materials, and options please refer to the product description of valve models 370b and 320b.

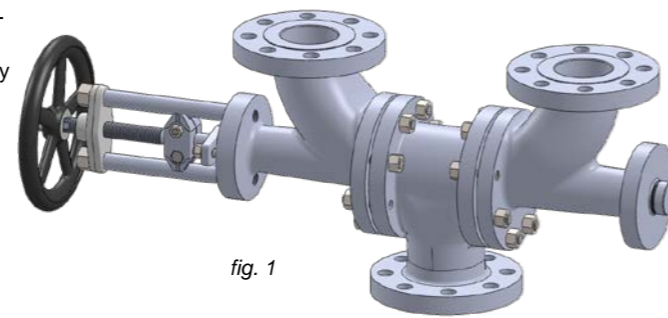

fig. 1

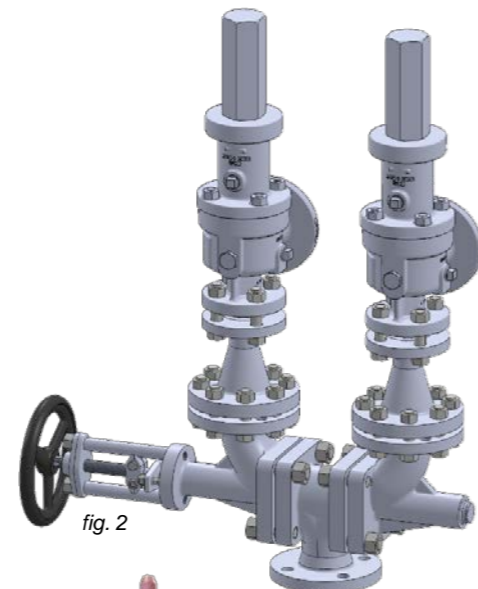

fig. 2



fig. 3



Design features

Advantages of the latest Phönix Change Over Valve generation

- Superior flow behaviours and a low pressure loss verified by using 3D flow behaviour simulations and practical Kv and zeta measurements. Zeta values < 0,8 are achieved
- Optimization of the body interior and the trim parts
- Optimization of the deflection angle < 30°
- Compact height, therefore a short pipe feed to the safety relief valve
- No sharp passages that might cause flow disruption

Phönix optimized COV design

Flow path deflection angle < 30°

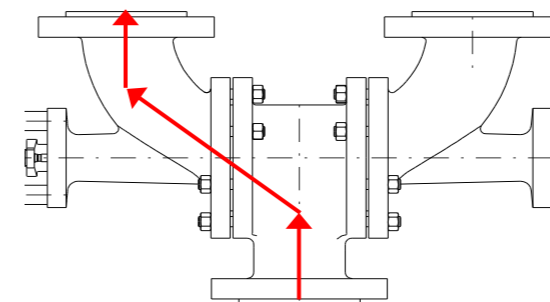

standard design

Flow path deflection angle 90°

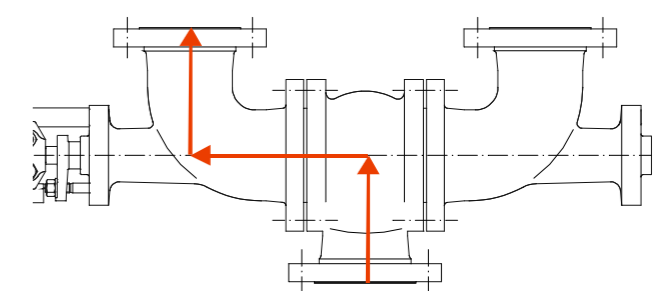

Basics

The pressure drop in the feeding pipe towards the safety relief valve, considering the highest set mass flow listed in international rules and standards, is not allowed to exceed 3% of the pressure difference between set-to-operate pressure and the superimposed back pressure. Pressure drop in the feeding pipe is meant to be the pressure difference between the pressure in the tank and the pressure right upfront of the safety relief valve.

This is also meant for combinations of change over and safety relief valves. The change over valve is part of the feeding pipe! AD 2000 A2; ASME Section VIII Division 1 ug-135

Drag coefficient zeta

In order to calculate the pressure drop you need to have the drag coefficient zeta. The drag coefficient zeta is a dimensional coefficient for the flow resistivity of a medium passed through component within the pipe. The intention is to have this drag coefficient the lowest possible. The very low drag coefficient for the latest generation of the Phönix change over valves is assured by the following:

- Design and calculation with modern 3D cad- and flow-simulation programs
- Practical Cv measurements, zeta determination on the Phönix (in house!) Cv-measurement and test area
- Practical Cv measurements, zeta determination using also flow measurement areas from partners like universities and engineering companies



Change Over Valve combination (COVC)

Phönix COVC with safety relief valves

The pressure drop in the feeding pipe towards the safety relief valve, considering the highest set mass flow listed in international rules and standards, is not allowed to exceed 3% of the pressure difference between set-to-operate pressure and the superimposed back pressure. Pressure drop in the feeding pipe is meant to be the pressure difference between the pressure in the tank and the pressure right upfront of the safety relief valve.

Interlockable combinations

Interlockable combinations are those that have a Change Over Valve at the inlet and at the outlet of a safety relief valve. It is necessary that both the change over valves have the same valve size and diameter to assure important dimensions being equal e.g. the stroke of the change over valve. The sizing of the change over valve is performed by using the one that is connected at the outlet of the safety relief valve

Both COVS will be adjusted to each other during the assembly into the line and afterwards connected via chain at the chainwheel. This assures that the stand by safety relief valve is cut off from the medium at the inlet and at the outlet.

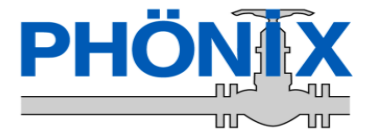
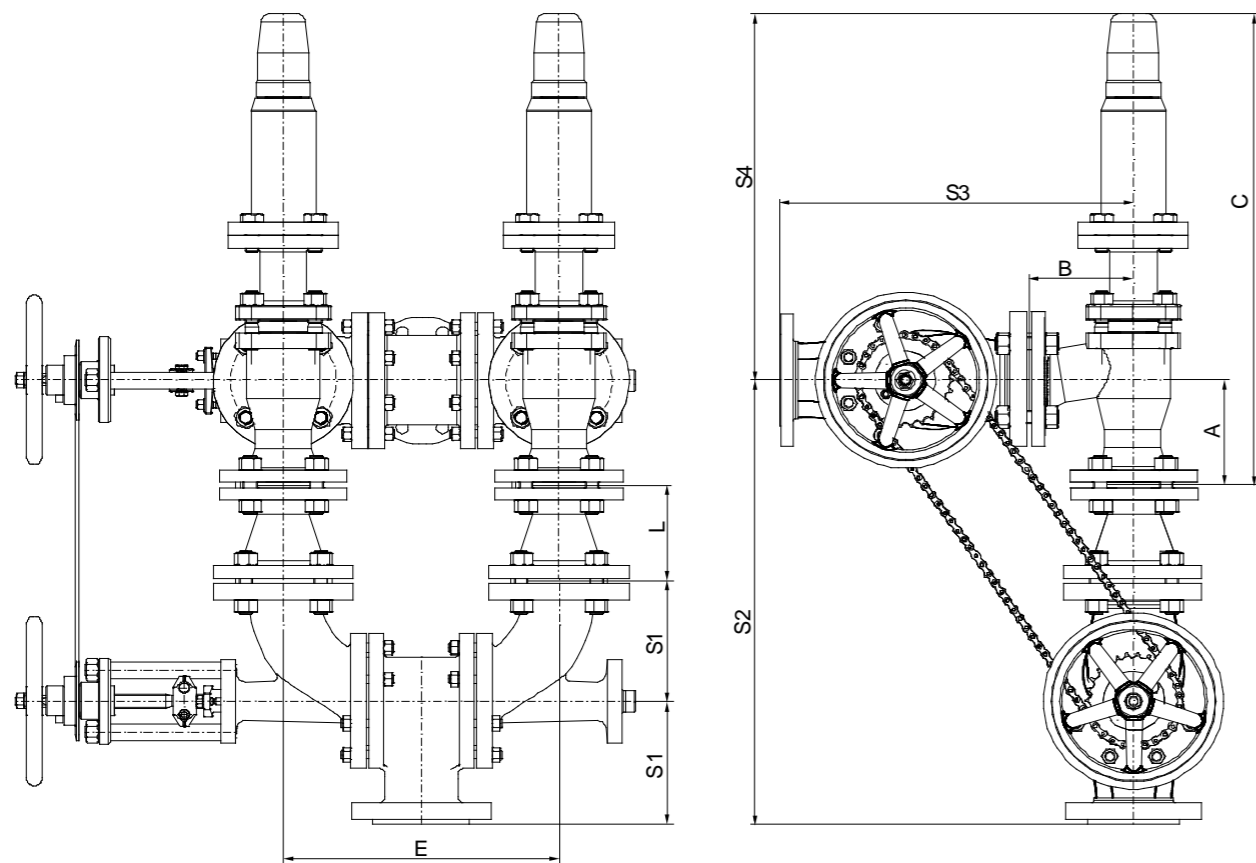

Applications & design features

Applications

The 370B series is designed for dual relief valve systems to allow maintenance of the relief valves without the system being down, for reduction of vessel connections, for fast and easy operation, and for protection against involuntary isolation of both safety relief devices at the same time. For applications that require discharge into a collecting system model 370.1B provides a simple mechanism for the linkage of two Change Over Valves for simultaneous operation.

Model 370B & 370.1B are designed for critical service applications involving lethal, toxic, corrosive, inflammable, volatile, radiating, or expensive fluids.

The most common applications are

- Dry chlorine (Cl₂)
- Anhydrous hydrogen chloride (HCl)
- Anhydrous hydrofluoric acid (HF)
- Phosgene (CoCl₂)
- Vinyl chloride monomer (VCM)
- Ethylene dichloride (EDC)
- Propane, butane, natural gas
- Fluids of similar nature.

Model 370B & 370.1B replaces conventional three-way valves that cannot provide such reliable and excellent protection against leaks or fugitive emissions. The stem seal requires virtually no maintenance due to leak free weld connections of the bellows with bonnet and stem. Constant valve monitoring and re-adjustment of the packing is eliminated. In the unlikely event of a bellows failure the backup packing guarantees safe valve performance until the next scheduled shutdown.

Design features

Bellows and packing

- Multiple walls and hydroformed bellows
- Welded to body and stem for zero leakage
- Up to 50.000 bellows operations guaranteed
- Bellows are protected from the flow and encapsulated in the bonnet

Body and bonnet

- split-body design allows for rotation of elbows to any 90° angle to accommodate different installation situation
- body bonnet joint gasket is fully confined to prevent gasket flow or blowout

Seats

- solid hardfacings for outstanding corrosion and wear resistance
- knife edge metal-to-metal seat for bubble-tight shutoff
- replaceable disc for inexpensive maintenance

Stem

- Two-piece stem protects the bellows against torque stress
- Design eliminates stem bearings along with their maintenance needs
- allows easy adaption for any type of actuation

= Zero emissions, zero seat leakage, low maintenance

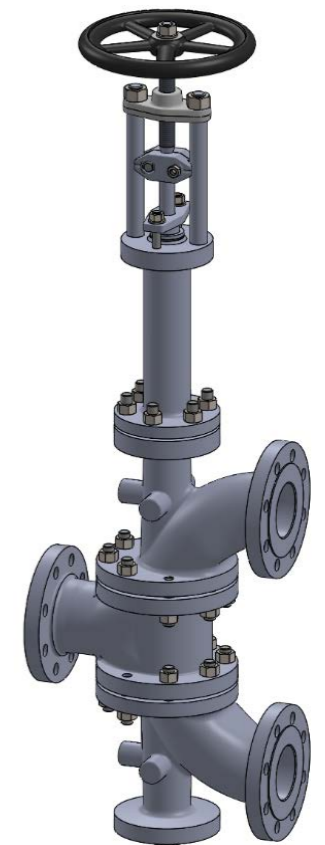



Standard Materials of Construction

Design / Testing / Marking

- PED 2014/68/EU, AD 2000 (A2), marking acc. to EN19, AD-A4
- Standard tests acc. to DIN EN12266, ISO 5208
- Preservation acc. to manufacturer standard
- Connections:
 - flanges acc. to DIN EN 1092-1
 - butt weld ends acc. to DIN EN 12627
 - socket weld ends acc. to DIN EN 12760
- F-t-F dimensions: manufacturer standard
- Pressure temperature ratings are in accordance to DIN EN 1092-1

Option

Other materials per customer requirements are available!

Notes

Phönix reserves the right to change product design and specification without notice!

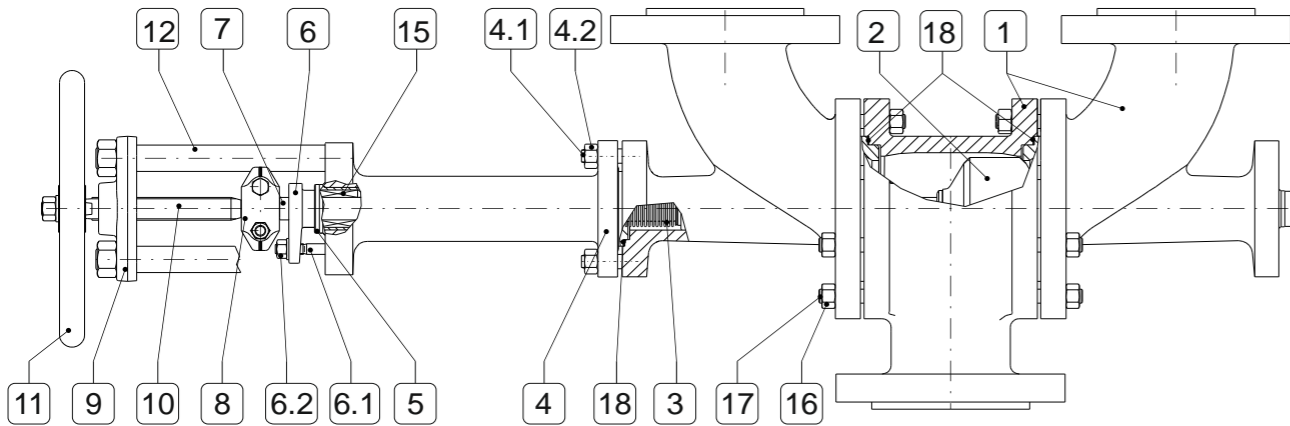

Materials

Item	Part Name	Carbon steel Model 370B C up to 450°C	low temp. Carbon steel Model 370B T -50°C up to 300°C	Stainless steel Model 370B V -200°C up to 400°C
1	Body	1.0460 / 1.0619	1.0566 / 1.1138	1.4404 / 1.4408
	Seat overlay	1.4370 (≈ 200HRB)	1.4370 (≈ 200HRB)	like body (≈ 200HRB)
2	Disc	1.4021 hardened / 1.0460	1.4571 / 1.0566	1.4571
	Overlay	1.4009 (≈ 300HRB)	Stellite 6 (≈ 42HRC)	Stellite 6 (≈ 42HRC)
3	Bellows	1.4571	1.4571	1.4571
4	Bonnet	1.0619	1.1138	1.4408
4.1/ 17	Stud bolt	1.7709	A4-70	A4-70
4.2/ 16	Hex. nut	1.7218	A4-70	A4-70
5	Packing sleeve	1.4571	1.4571	1.4571
6	Gland follower	1.0619	1.5638	1.4408
6.1	Stud bolt	Steel 5.6	A4-70	A4-70
6.2	Hex. nut	Steel 5	A4-70	A4-70
7	Lower stem	1.4571	1.4571	1.4571
8	Coupling	1.4408	1.4408	1.4408
9	Bridge	1.0460, QPQ-nitrided	1.0460, QPQ-nitrided	1.0460, QPQ-nitrided
10	Upper stem	1.4057	1.4057	1.4057
11	Handwheel	Cast iron	Cast iron	Cast iron
12	Pillar	1.0501	1.4057	1.4057
15	Packing	Graphite	PTFE-silk *	Graphite
18	Gasket	Grooved SS / graphite	Grooved SS / graphite	Grooved SS / graphite

* 3 220°C Packing of pure graphite



PN40 Sizes DN15 - DN500

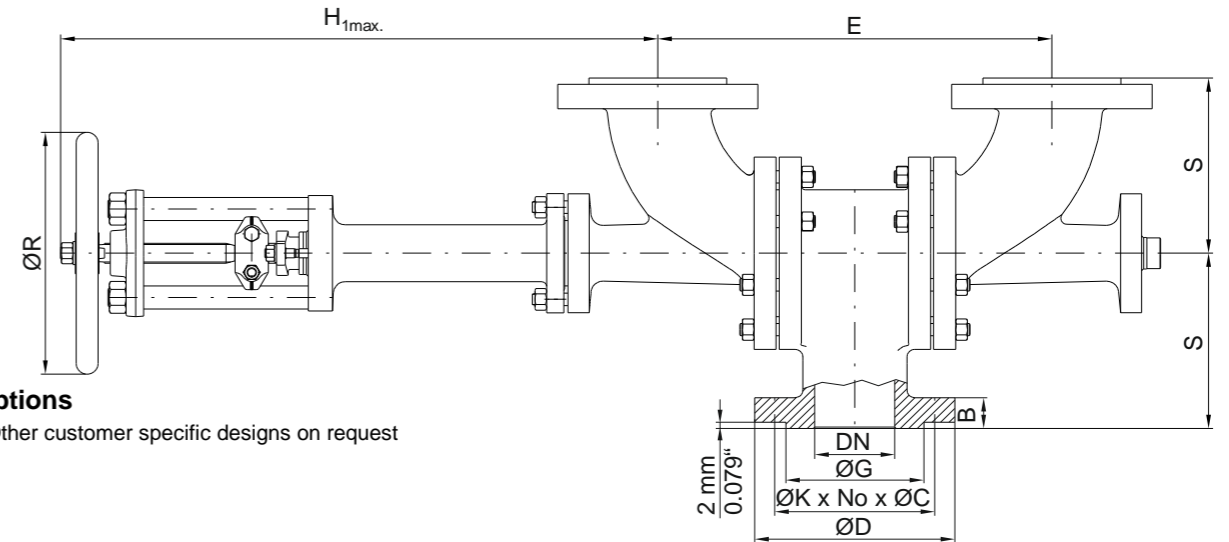

Options

- Other customer specific designs on request

Dimensions & Weights & Flow Coefficients

DN	Unit	E	S	Hmax. 370B	Hmax. 370B.1	ØR	ØG	ØK	No x ØC	ØD	B	Weight 370B	Weight 370B.1	Kv [m³/h]	cv [USGal/min]	ζ [-]
15	[mm] [in]	147 5.79	90 3.54	385 15.16	405 15.94	150 5.91	45 1.77	65 2.56	4 x 14 4 x 0.55	95 3.74	16 0.63	16 kg 35 lbs	20 kg 44 lbs	11 12.79		0.8
20	[mm] [in]	147 5.79	90 3.54	385 15.16	405 15.94	150 5.91	58 2.28	75 2.95	4 x 14 4 x 0.55	105 4.13	18 0.71	16 kg 35 lbs	20 kg 44 lbs	18 20.93		0.8
25	[mm] [in]	147 5.79	90 3.54	385 15.16	405 15.94	150 5.91	68 2.68	85 3.35	4 x 14 4 x 0.55	115 4.53	18 0.71	16.5 kg 36 lbs	21 kg 46 lbs	32 37		0.8
32	[mm] [in]	260 10.24	130 5.12	575 22.64	615 24.21	200 7.87	78 3.07	100 3.94	4 x 18 4 x 0.71	140 5.51	18 0.71	36 kg 79 lbs	39 kg 86 lbs	46 53		0.8
40	[mm] [in]	260 10.24	130 5.12	575 22.64	615 24.21	200 7.87	88 3.46	110 4.33	4 x 18 4 x 0.71	150 5.91	18 0.71	38 kg 84 lbs	40 kg 88 lbs	72 84		0.8
50	[mm] [in]	260 10.24	130 5.12	575 22.64	615 24.21	200 7.87	102 4.02	125 4.92	4 x 18 4 x 0.71	165 6.50	20 0.79	39 kg 86 lbs	41 kg 90 lbs	110 128		0.83
65	[mm] [in]	404 15.91	180 7.09	770 30.31	735 28.94	250 9.84	122 4.80	145 5.71	8 x 18 8 x 0.71	185 7.28	22 0.87	84 kg 185 lbs	89 kg 196 lbs	210 244		0.7
80	[mm] [in]	404 15.91	180 7.09	770 30.31	735 28.94	250 9.84	138 5.43	160 6.30	8 x 18 8 x 0.71	200 7.87	24 0.94	90 kg 198 lbs	95 kg 209 lbs	300 349		0.73
100	[mm] [in]	500 19.69	220 8.66	860 33.86	825 32.48	315 12.40	162 6.38	190 7.48	8 x 22 8 x 0.87	235 9.25	24 0.94	144 kg 317 lbs	149 kg 328 lbs	430 500		0.87
125	[mm] [in]	500 19.69	220 8.66	860 33.86	820 32.28	400 15.75	188 7.40	220 8.66	8 x 26 8 x 1.02	270 10.63	26 1.02	155 kg 342 lbs	163 kg 359 lbs	430 500		0.87
150	[mm] [in]	760 29.92	320 12.60	1125 44.29	1145 45.08	400 15.75	218 8.58	250 9.84	8 x 26 8 x 1.02	300 11.81	28 1.10	353 kg 778 lbs	359 kg 791 lbs	960 1116		0.88
200	[mm] [in]	1019 40.12	430 16.93	1490 58.66	1635 64.37	640 25.20	285 11.22	320 12.60	12 x 30 12 x 1.18	375 14.76	34 1.34	773 kg 1704 lbs	823 kg 1814 lbs	1835 2134		0.75
250	[mm] [in]	1259 49.57	580 22.83	1890 74.41	2020 79.53	640 25.20	345 13.58	385 15.16	12 x 33 12 x 1.30	450 17.72	38 1.50	1237 kg 2727 lbs	1287 kg 2837 lbs	2620 3047		0.9
300	[mm] [in]	On request														
350	[mm] [in]															
400	[mm] [in]															
450	[mm] [in]															
500	[mm] [in]															

Contact us

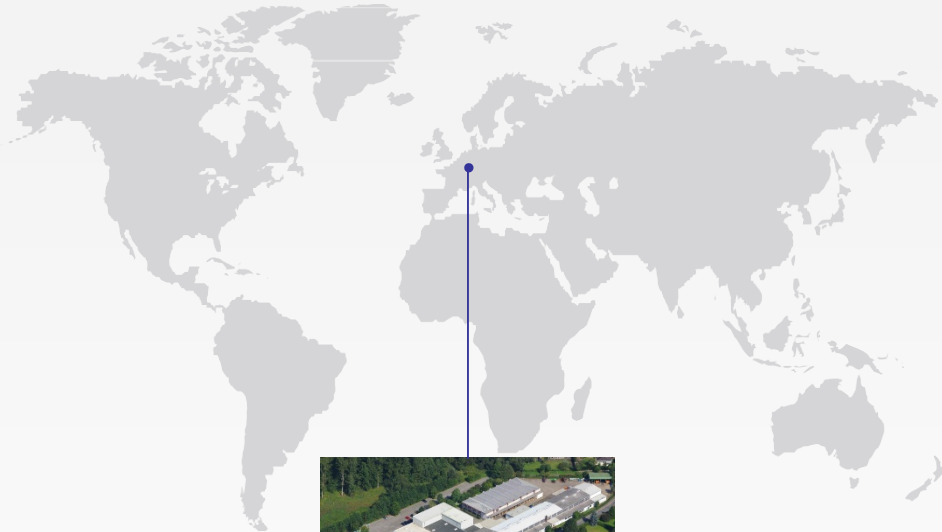

Volkmarsen, Germany

Sales and Operations

Phönix Valve Group GmbH

Volkmarsen, Germany
Phone: +49 5693 988 0
Email: info@phoenix-valvegroup.com
Website: www.phoenix-valvegroup.com

Phönix Armaturen Werke-Bregel GmbH

Volkmarsen, Germany
Phone: +49 5693 988 0
Email: info@phoenix-valvegroup.com
Website: www.phoenix-valvegroup.com

Strack GmbH

Volkmarsen, Germany
Phone: +49 5693 988 0
Email: info@phoenix-valvegroup.com
Website: www.phoenix-valvegroup.com

PAW SARL

Genay Cedex, France
Phone: +33 437 408 195
Email: commercial@phoenix-valvegroup.com
Website: www.phoenix-valvegroup.com

Daume Regelarmaturen GmbH

Volkmarsen, Germany
Phone: +49 5693 988 0
Email: info@phoenix-valvegroup.com
Website: www.phoenix-valvegroup.com

Solent & Pratt Phönix Ltd.

Volkmarsen, Germany
Phone: +49 5693 988 0
Email: info@phoenix-valvegroup.com
Website: www.phoenix-valvegroup.com



While this information is presented in good faith and believed to be accurate, Phönix Valve Group GmbH, does not guarantee satisfactory results from reliance on such information. Nothing contained herein is to be construed as a warranty or guarantee, expressed or implied, regarding the performance, merchantability, fitness or any other matter with respect to the products, nor as a recommendation to use any product or process in conflict with any patent. Phönix Valve Group GmbH, reserves the right, without notice, to alter or improve the designs or specifications of the products described herein.

© 2022 Phönix Valve Group. All rights reserved. Specifications are subject to change without notice. All trademarks are property of their respective owners

Printed in Germany
09/22-R0