



**PHÖNIX**

**STRACK**

**DAUME**  
REGELARMATUREN



**Solent & Pratt**  
Phönix Ltd

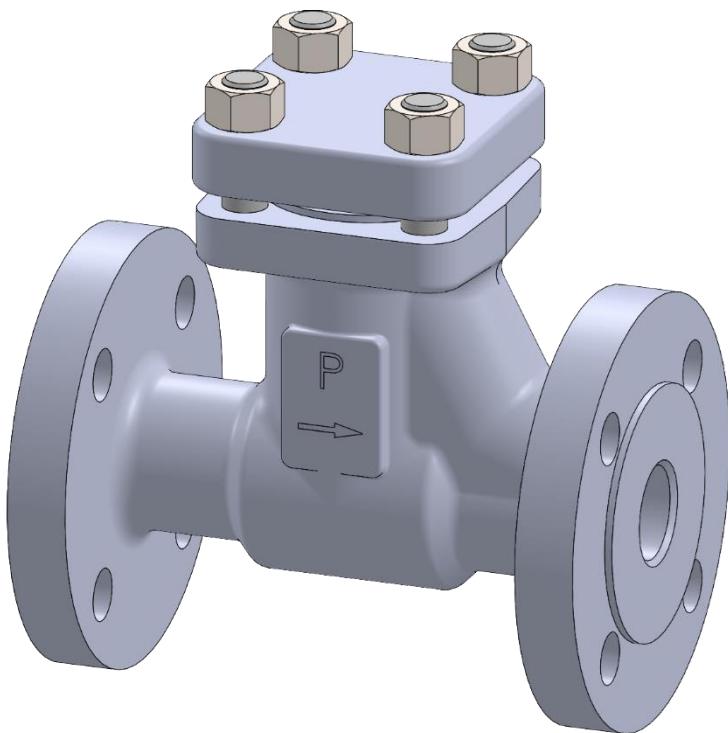

# Check Valve

## Type 420

### PN 16 - 160

Phönix Valve Group  
Am Stadtbruch 6  
34471 Volkmarsen

Phone:  
web:  
eMail:

+49 5693 988 0  
[www.phoenix-valvegroup.com](http://www.phoenix-valvegroup.com)  
[info@phoenix-valvegroup.com](mailto:info@phoenix-valvegroup.com)



# Check Valve / Type 420

DN 15 - 250  
PN 16 / 25 / 40 / 63 / 100 / 160



## Design

Replaceable disc with flat metal-to-metal seal

Available with or without pressure spring

Opening at a differential pressure of 0,05 bar

CE 0525

## Dimensions

≤ PN 40	Size / DN	15	20	25	32	40	50	65	80	100	125	150	200	250
	L	130	150	160	180	200	230	290	310	350	400	480	600	730
	H	115	115	115	165	165	165	145	145	165	220	225	255	300
	D	-	-	-	-	-	-	-	-	-	-	-	-	-
	Weight ( kg )	3,6	4	4,5	10	12	15	20	28	40	66	92	190	285

PN 63	Size / DN	15	20	25	32	40	50	65	80	100	125	150	200	250
	L	210	230	230	260	260	300	340	380	430	-	550	-	-
	H	115	115	115	150	150	150	155	180	200	-	235	-	-
	D	-	-	-	-	-	-	-	-	-	-	-	-	-
	Weight ( kg )	5	6	6	12	14	16	22	30	42	-	100	-	-

PN 100-160	Size / DN	15	20	25	32	40	50	65	80	100	125	150	200	250
	L	210	230	230	260	260	300	340	380	430	-	-	-	-
	H	115	115	115	150	150	150	155	180	200	-	-	-	-
	D	-	-	-	-	-	-	-	-	-	-	-	-	-
	Weight ( kg )	5	6	6	12	14	16	22	30	42	-	-	-	-

## Drag coefficient / Flow coefficient

Size / DN	15	20	25	32	40	50	65	80	100	125	150	200	250
$\zeta_v$ [-]	6,9	5,1	8,9	5,1	9,1	10	4,6	5	4,9	5,9	4,9	5,2	5,6
$k_v$ [m <sup>3</sup> /h]	3,4	7	8,3	18	21	31	78	113	179	256	405	693	1047

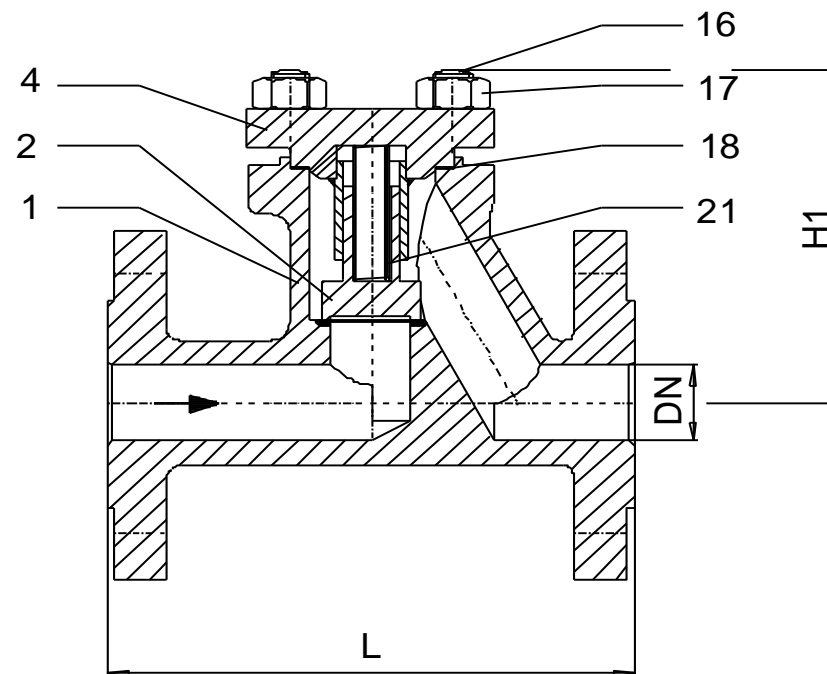

PHÖNIX reserves the right to change product design and specification without notice.

PHÖNIX • P +49 5693 988-0 • F +49 5693 988-178 • info@phoenix-valvegroup.com • https://phoenix-valvegroup.com

# Check Valve / Type 420

PN16 / 25 / 40 / 63 / 100 / 160 DN15 - DN250

## Materials



Item	Part name	Heat resistant carbon steel / Type 420 C		Low temperature steel / Type 420 T		Stainless steel / Type 420 V	
		Material * up to 450°C	DIN	Material * from -50°C up to 300°C	DIN	Material * from -200°C up to 400°C	DIN
1	Body	P250GH	1.0460	P355NL1	1.0566	X 2CrNiMo17-12-2	1.4404
		GP240GH	1.0619	G21Mn 5	1.1138	GX5CrNiMo19-11-2	1.4408
	Overlay	G 18 8Mn (≈ 200 HRB)	1.4370	G 18 8Mn (≈ 200 HRB)	1.4370	-	-
2	Disc	X20Cr13	1.4021	X 6CrNiMoTi17-12-2	1.4571	X 6CrNiMoTi17-12-2	1.4571
		P250GH	1.0460	P355NL1	1.0566	X 6CrNiMoTi17-12-2	1.4571
	Overlay	G Z 13 (≈ 300 HRB)	1.4009	Stellite 6 (≈ 42 HRC)		Stellite 6 (≈ 42 HRC)	
4	Bonnet	P250GH	1.0460	P355NL1	1.0566	X 2CrNiMo17-12-2	1.4404
		GP240GH	1.0619	G21Mn 5	1.1138	X 2CrNiMo17-12-2	1.4404
16	Stud bolt	21CrMoV5-7	1.7709	A4-70		A4-70	
17	Hex.nut	25CrMo4	1.7218	A4-70		A4-70	
18	Bonnet gasket	Graphite + S.S.		Graphite + S.S.		Graphite + S.S.	
21	Compression spring	X 6CrNiMoTi17-12-2	1.4571	X 6CrNiMoTi17-12-2	1.4571	X 6CrNiMoTi17-12-2	1.4571

Special materials on request.

\* Pressure-temperature-rating see appendix

## Specification

Marking	EN19, AD-A4, CE
Face-to-face dimensions	
Flanged option	DIN EN 558-1
Butt weld ends	DIN EN 12982 up to PN100
Socket weld ends	
Connections	
Flanged option	DIN EN 1092-1 up to PN100 / DIN 2512 PN160
Butt weld ends	DIN EN 12627
Socket weld ends	DIN EN 12760
Testing standard	AD-2000, DIN 3230 section 3, DIN EN 12266

PHÖNIX reserves the right to change product design and specification without notice.

PHÖNIX • P +49 5693 988-0 • F +49 5693 988-178 • info@phoenix-valvegroup.com • https://phoenix-valvegroup.com

# Contact us

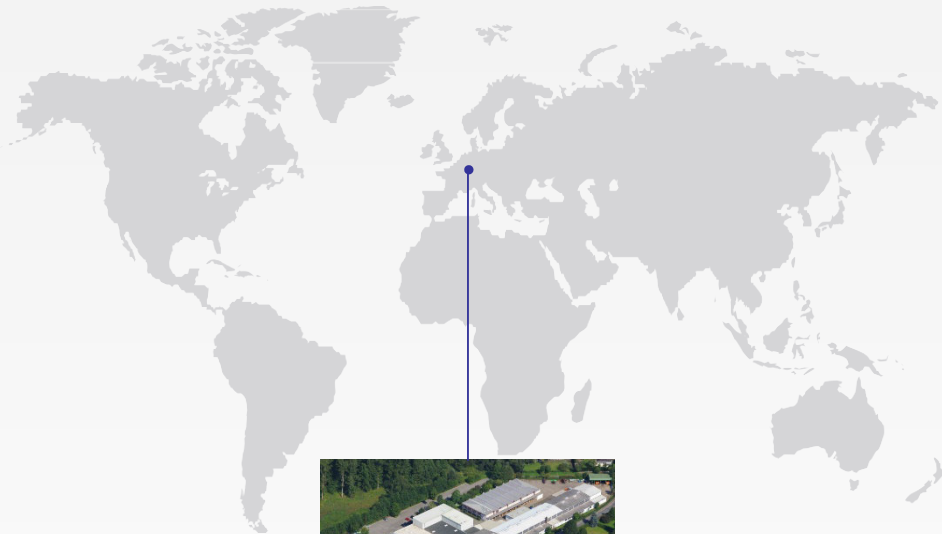

Volkmarsen, Germany

## Sales and Operations

### Phönix Valve Group GmbH

Volkmarsen, Germany  
Phone: +49 5693 988 0  
Email: [info@phoenix-valvegroup.com](mailto:info@phoenix-valvegroup.com)  
Website: [www.phoenix-valvegroup.com](http://www.phoenix-valvegroup.com)

### Phönix Armaturen Werke-Bregel GmbH

Volkmarsen, Germany  
Phone: +49 5693 988 0  
Email: [info@phoenix-valvegroup.com](mailto:info@phoenix-valvegroup.com)  
Website: [www.phoenix-valvegroup.com](http://www.phoenix-valvegroup.com)

### Strack GmbH

Volkmarsen, Germany  
Phone: +49 5693 988 0  
Email: [info@phoenix-valvegroup.com](mailto:info@phoenix-valvegroup.com)  
Website: [www.phoenix-valvegroup.com](http://www.phoenix-valvegroup.com)

### PAW SARL

Genay Cedex, France  
Phone: +33 437 408 195  
Email: [commercial@phoenix-valvegroup.com](mailto:commercial@phoenix-valvegroup.com)  
Website: [www.phoenix-valvegroup.com](http://www.phoenix-valvegroup.com)

### Daume Regelarmaturen GmbH

Volkmarsen, Germany  
Phone: +49 5693 988 0  
Email: [info@phoenix-valvegroup.com](mailto:info@phoenix-valvegroup.com)  
Website: [www.phoenix-valvegroup.com](http://www.phoenix-valvegroup.com)

### Solent & Pratt Phönix Ltd.

Volkmarsen, Germany  
Phone: +49 5693 988 0  
Email: [info@phoenix-valvegroup.com](mailto:info@phoenix-valvegroup.com)  
Website: [www.phoenix-valvegroup.com](http://www.phoenix-valvegroup.com)



While this information is presented in good faith and believed to be accurate, Phönix Valve Group GmbH, does not guarantee satisfactory results from reliance on such information. Nothing contained herein is to be construed as a warranty or guarantee, expressed or implied, regarding the performance, merchantability, fitness or any other matter with respect to the products, nor as a recommendation to use any product or process in conflict with any patent. Phönix Valve Group GmbH, reserves the right, without notice, to alter or improve the designs or specifications of the products described herein.

© 2022 Phönix Valve Group. All rights reserved. Specifications are subject to change without notice. All trademarks are property of their respective owners

Printed in Germany  
09/22-R0