



**PHÖNIX**

**STRACK**

**DAUME**  
REGELARMATUREN



**Solent & Pratt**  
Phoenix Ltd

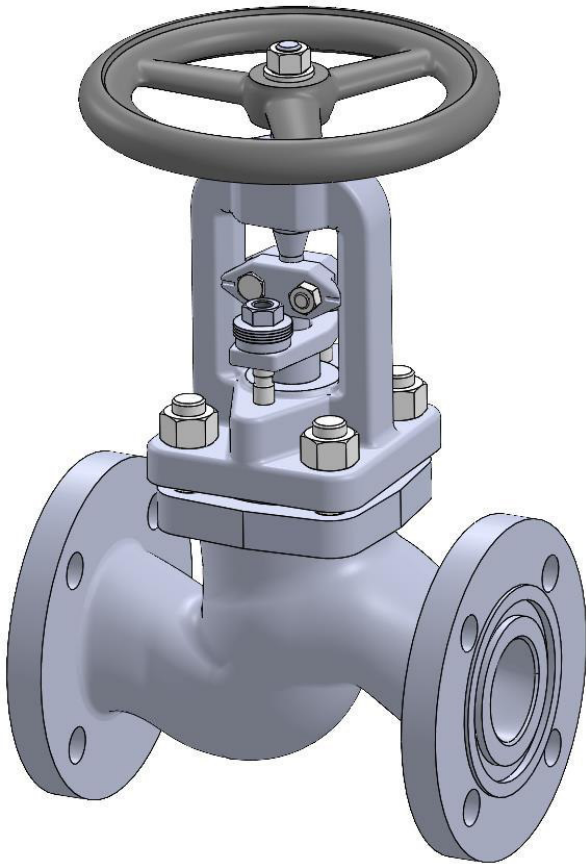

# Globe Valve

## Type 430.1

### PN 40

Phönix Valve Group  
Am Stadtbruch 6  
34471 Volkmarsen

Phone:  
web:  
eMail:

+49 5693 988 0  
[www.phoenix-valvegroup.com](http://www.phoenix-valvegroup.com)  
[info@phoenix-valvegroup.com](mailto:info@phoenix-valvegroup.com)



# Globe Valve / Type 430.1 Spring Loaded Stuffing Box

## PN40 DN15 - DN150

CE 0525

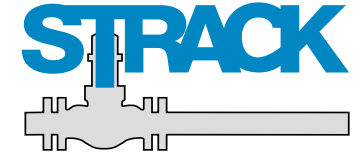

### Design

- Stem sealed spring loaded stuffing box which enables a permanent and uniform compression of the packing
- Additional back seat at fully opened valve
- Spring unit protected against environment corrosion
- Rising handwheel
- Rotating disc with conic metal-to-metal seal

### Dimensions

PN 40	Size / DN	15	20	25	32	40	50	65	80	100	125	150
	L	130	150	160	180	200	230	290	310	350	400	480
	H	275	255	275	315	315	350	415	475	555	555	720
	D	150	150	150	200	200	200	200	250	315	315	400
	Weight ( kg )	5,5	7	7	10	13	15	23	30	50	85	110

Attention: italic nominal width with equilibrating disc, see appendix

### Drag coefficient / Flow coefficient

Size / DN	15	20	25	32	40	50	65	80	100	125	150
$\zeta_v$ [-]	6,2	4,7	7,7	5,7	5,5	9,7	4,9	5,2	5	5,4	5,5
$k_v$ [m <sup>3</sup> /h]	3,6	7,4	9	17	27	32	76	112	174	267	375

PHÖNIX reserves the right to change product design and specification without notice.

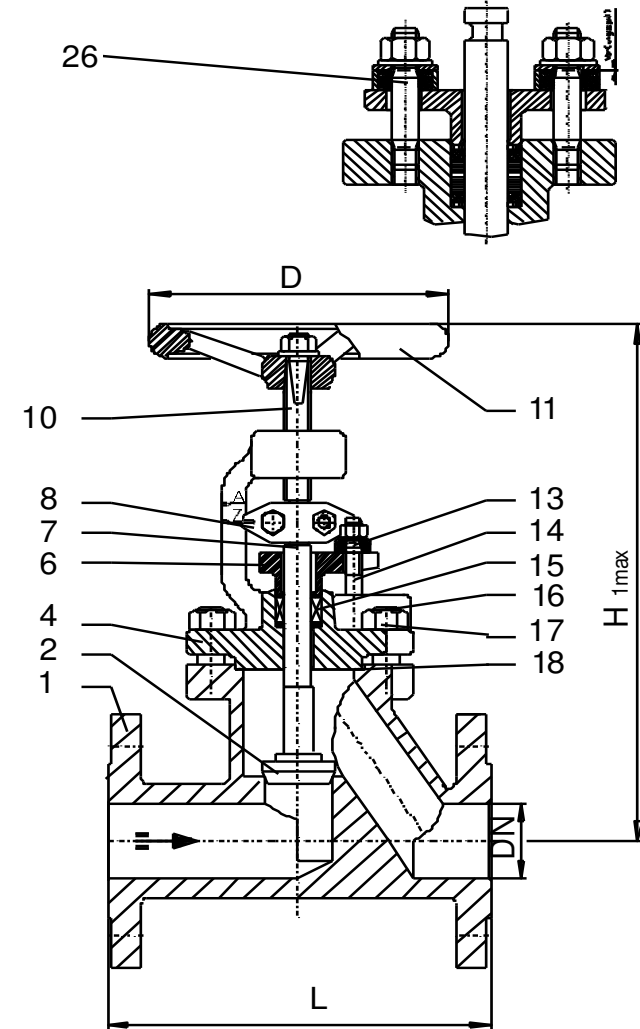

# Globe Valve / Type 430.1 Spring Loaded Stuffing Box

PN16-PN160 DN15 - DN150

## Materials



Item	Part name	Heat resistant carbon steel / Type 430.1 C		Stainless steel / Type 430.1V	
		Material * up to 450°C	DIN	Material * from -200°C up to 400°C	DIN
1	Body	P250GH G 18 8Mn (≈ 200 HRB)	1.0460	X2CrNiMo17-12-2	1.4404
	Overlay	GP240GH G 18 8Mn (≈ 200 HRB)	1.0619	GX5CrNiMo19-11-2 -	1.4408 -
2	Disc	X20Cr13 hardened	1.4021	X6CrNiMoTi17-12-2	1.4571
	Overlay	P250GH G Z 13 (≈ 300 HRB)	1.0460 1.4009	Stellite 6 (≈ 42 HRC)	
4	Bonnet ≤ DN 65 > DN 65	P250GH	1.0460	X2CrNiMo17-12-2	1.4404
		GP240GH	1.0619	GX5CrNiMo19-11-2	1.4408
6	Gland follower	GP240GH	1.0619	X6CrNiMoTi17-12-2	1.4571
7	Lower stem	X6CrNiMoTi17-12-2	1.4571	X6CrNiMoTi17-12-2	1.4571
8	Coupling	GX5CrNiMo19-11-2	1.4408	GX5CrNiMo19-11-2	1.4408
10	Upper stem	X17CrNi16-2	1.4057	X17CrNi16-2	1.4057
11	Handwheel	EN-GJS-400-15	0.7040	EN-GJS-400-15	0.7040
13	Hex.nut	Steel	5	A4-70	
14	Stud bolt	Steel	5.6	A4-70	
15	Packing	Graphite		Graphite	
16	Stud bolt	21CrMoV5-7	1.7709	A4-70	
17	Hex.nut	25CrMo4	1.7218	A4-70	
18	Bonnet gasket	Kammprofil / Graphite + S.S.		Kammprofil / Graphite + S.S.	
26	Disc spring package	50 CrV 4	1.8159	50 CrV 4	1.8159

### Special materials on request.

Marking EN19, AD-A4, CE

Face-to-face dimensions

Flanged option

Butt weld ends

Socket weld ends

Connections

Flanged option

Butt weld ends

Socket weld ends

Testing standard

AD-2000, DIN 3230 section 3, DIN EN 12266

PHÖNIX reserves the right to change product design and specification without notice.

\* Pressure-temperature-rating see appendix

\*\* ≥ 220°C Packing of pure graphite

# Contact us



Volkmarsen, Germany

## Sales and Operations

### Phönix Valve Group GmbH

Volkmarsen, Germany  
Phone: +49 5693 988 0  
Email: [info@phoenix-valvegroup.com](mailto:info@phoenix-valvegroup.com)  
Website: [www.phoenix-valvegroup.com](http://www.phoenix-valvegroup.com)

### Phönix Armaturen Werke-Bregel GmbH

Volkmarsen, Germany  
Phone: +49 5693 988 0  
Email: [info@phoenix-valvegroup.com](mailto:info@phoenix-valvegroup.com)  
Website: [www.phoenix-valvegroup.com](http://www.phoenix-valvegroup.com)

### Strack GmbH

Volkmarsen, Germany  
Phone: +49 5693 988 0  
Email: [info@phoenix-valvegroup.com](mailto:info@phoenix-valvegroup.com)  
Website: [www.phoenix-valvegroup.com](http://www.phoenix-valvegroup.com)

### PAW SARL

Genay Cedex, France  
Phone: +33 437 408 195  
Email: [commercial@phoenix-valvegroup.com](mailto:commercial@phoenix-valvegroup.com)  
Website: [www.phoenix-valvegroup.com](http://www.phoenix-valvegroup.com)

### Daume Regelarmaturen GmbH

Volkmarsen, Germany  
Phone: +49 5693 988 0  
Email: [info@phoenix-valvegroup.com](mailto:info@phoenix-valvegroup.com)  
Website: [www.phoenix-valvegroup.com](http://www.phoenix-valvegroup.com)

### Solent & Pratt Phönix Ltd.

Volkmarsen, Germany  
Phone: +49 5693 988 0  
Email: [info@phoenix-valvegroup.com](mailto:info@phoenix-valvegroup.com)  
Website: [www.phoenix-valvegroup.com](http://www.phoenix-valvegroup.com)



While this information is presented in good faith and believed to be accurate, Phönix Valve Group GmbH, does not guarantee satisfactory results from reliance on such information. Nothing contained herein is to be construed as a warranty or guarantee, expressed or implied, regarding the performance, merchantability, fitness or any other matter with respect to the products, nor as a recommendation to use any product or process in conflict with any patent. Phönix Valve Group GmbH, reserves the right, without notice, to alter or improve the designs or specifications of the products described herein.

© 2022 Phönix Valve Group. All rights reserved. Specifications are subject to change without notice. All trademarks are property of their respective owners

Printed in Germany  
09/22-R0