



PHÖNIX

STRACK

DAUME
REGELARMATUREN



Solent & Pratt
Phoenix Ltd

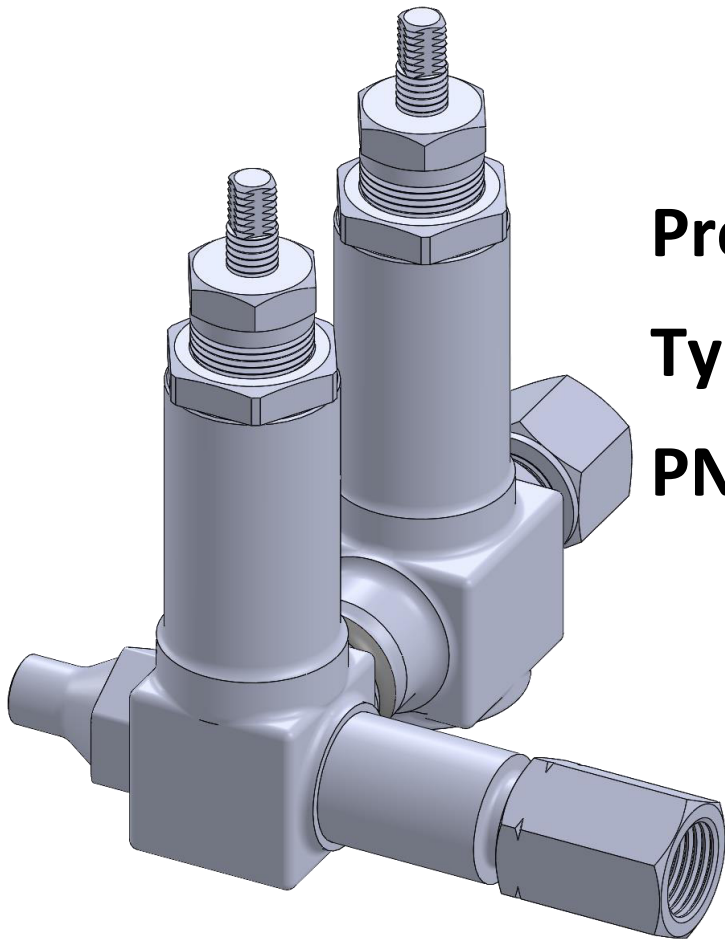

Pressure Gauge Twin Valve Type 589 PN 400

Phönix Valve Group
Am Stadtbruch 6
34471 Volkmarsen

Phone:
web:
eMail:

+49 5693 988 0
www.phoenix-valvegroup.com
info@phoenix-valvegroup.com



Pressure gauge twin valve / Type 589

DN 3,5
PN 400



Design

- Isolating valve, thru way type with lateral test connection
- Test connection to be locked separately by single valve
- Coupled divided stem with outside thread, rising stem
- Loose renewable disc and seat with conic metal-to-metal seal
- Stuffing box insert easy replaceable by bellows seal element
- Without vent screw, with T-handle

Dimensions

PN 400	Size / DN	3,5
	L	125
	H	133
	D	-
	Weight (kg)	2,5

Pressure-Temperature-Rating

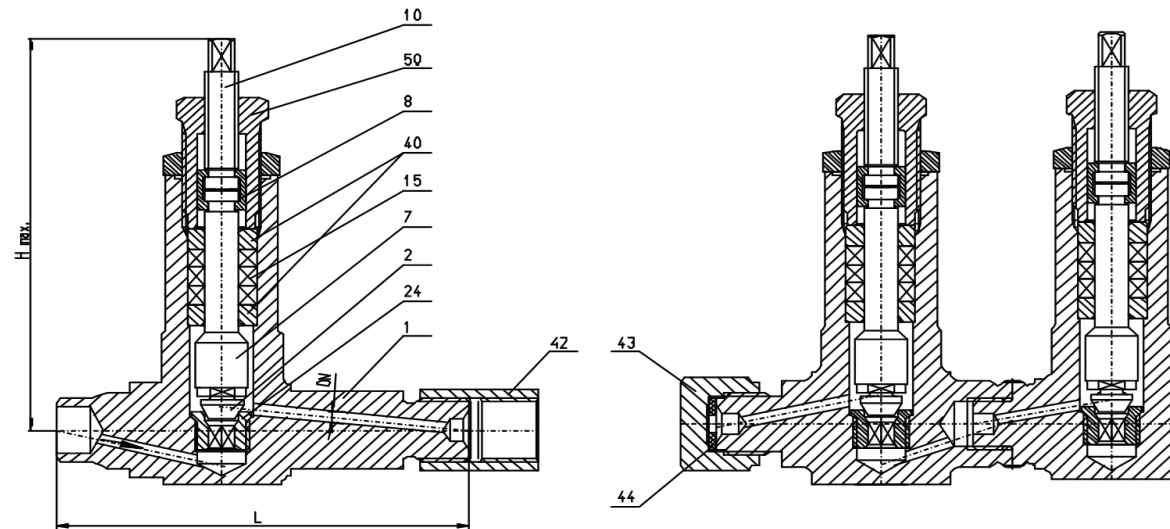
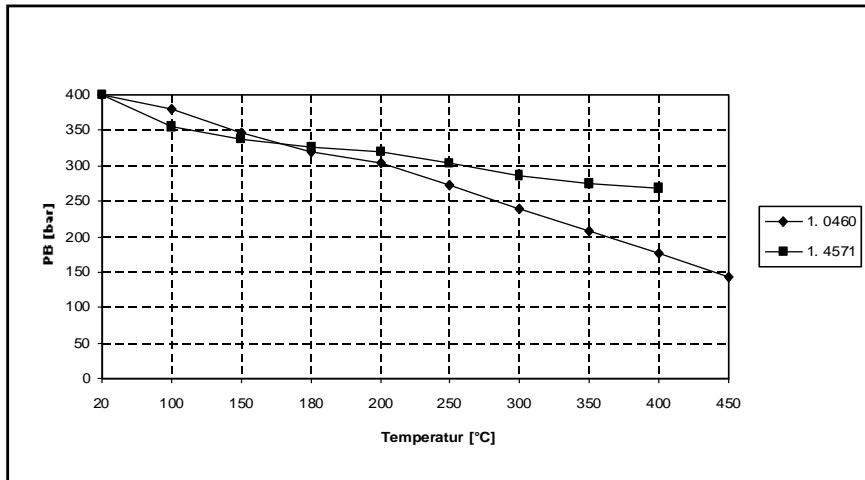

PHÖNIX reserves the right to change product design and specification without notice.

Pressure gauge twin valve / Type 589

PN 400 DN 3,5

Materials



Item	Part name	Heat resistant carbon steel / Type 589 C		Stainless steel / Type 589 V	
		Material up to 400°C	DIN	Material from -270°C up to 400°C	DIN
1	Body	P250GH	1.0460	X 6CrNiMoTi17-12-2	1.4571
2	Disc	X20Cr13	1.4021	Colmonoy 4	
7	Stem	X 6CrNiMoTi17-12-2	1.4571	X 6CrNiMoTi17-12-2	1.4571
8	Coupling	GX5CrNiNb19-10	1.4552	GX5CrNiNb19-10	1.4552
10	Upper stem	X17CrNi16-2	1.4057	X17CrNi16-2	1.4057
15	Packing	Pure graphite		Pure graphite	
24	Seat	X 6CrNiMoTi17-12-2	1.4571	X 6CrNiMoTi17-12-2	1.4571
40	Wiper	X 6CrNiMoTi17-12-2	1.4571	X 6CrNiMoTi17-12-2	1.4571
41	Pressure nut	X 6CrNiMoTi17-12-2	1.4571	X 6CrNiMoTi17-12-2	1.4571
42	Adjusting nut	X5CrNi18-10	1.4301	X5CrNi18-10	1.4301
43	Cap	X5CrNi18-10	1.4301	X5CrNi18-10	1.4301
44	Gasket		2.4060		2.4060

Special materials on request.

Specification

Marking	EN19, AD-A4	
Standard connections	Inlet:	Butt weld ends for pipe with outside diameter up to 25mm
	Outlet:	Male plug G1/2 with adjusting nut G1/2 left / right hand thread
	Test:	Male plug M20x1,5 with cap
Testing standard	AD-2000, DIN 3230 section 3, DIN EN 12266	

PHÖNIX reserves the right to change product design and specification without notice.

PHÖNIX • P +49 5693 988-0 • F +49 5693 988-178 • info@phoenix-valvegroup.com • https://phoenix-valvegroup.com

Contact us

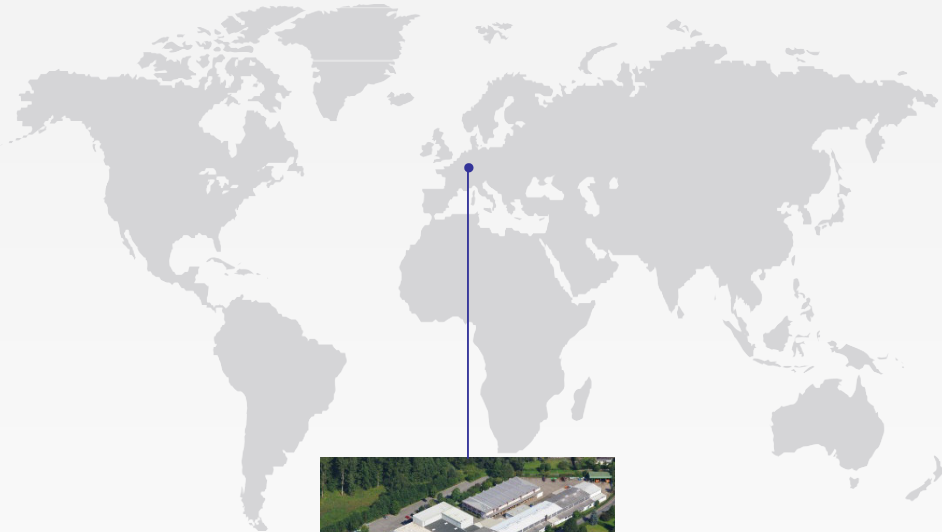

Volkmarsen, Germany

Sales and Operations

Phönix Valve Group GmbH

Volkmarsen, Germany
Phone: +49 5693 988 0
Email: info@phoenix-valvegroup.com
Website: www.phoenix-valvegroup.com

Phönix Armaturen Werke-Bregel GmbH

Volkmarsen, Germany
Phone: +49 5693 988 0
Email: info@phoenix-valvegroup.com
Website: www.phoenix-valvegroup.com

Strack GmbH

Volkmarsen, Germany
Phone: +49 5693 988 0
Email: info@phoenix-valvegroup.com
Website: www.phoenix-valvegroup.com

PAW SARL

Genay Cedex, France
Phone: +33 437 408 195
Email: commercial@phoenix-valvegroup.com
Website: www.phoenix-valvegroup.com

Daume Regelarmaturen GmbH

Volkmarsen, Germany
Phone: +49 5693 988 0
Email: info@phoenix-valvegroup.com
Website: www.phoenix-valvegroup.com

Solent & Pratt Phönix Ltd.

Volkmarsen, Germany
Phone: +49 5693 988 0
Email: info@phoenix-valvegroup.com
Website: www.phoenix-valvegroup.com



While this information is presented in good faith and believed to be accurate, Phönix Valve Group GmbH, does not guarantee satisfactory results from reliance on such information. Nothing contained herein is to be construed as a warranty or guarantee, expressed or implied, regarding the performance, merchantability, fitness or any other matter with respect to the products, nor as a recommendation to use any product or process in conflict with any patent. Phönix Valve Group GmbH, reserves the right, without notice, to alter or improve the designs or specifications of the products described herein.

© 2022 Phönix Valve Group. All rights reserved. Specifications are subject to change without notice. All trademarks are property of their respective owners

Printed in Germany
09/22-R0