



**PHÖNIX**

**STRACK**

**DAUME**  
REGELARMATUREN



**Solent & Pratt**  
Phoenix Ltd

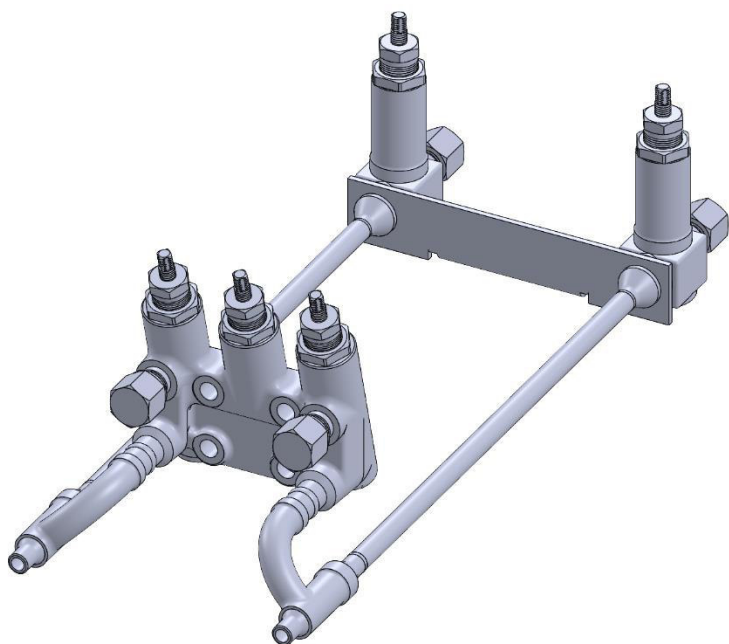

# Valve Combination Type 630 PN 400

Phönix Valve Group  
Am Stadtbruch 6  
34471 Volkmarsen

Phone:  
web:  
eMail:

+49 5693 988 0  
[www.phoenix-valvegroup.com](http://www.phoenix-valvegroup.com)  
[info@phoenix-valvegroup.com](mailto:info@phoenix-valvegroup.com)



# Valve combination - 5fold / Type 630

## Design

- Manifold combination with 5 valves
- Coupled divided stem with outside thread, operated with T-handle
- Bodies and transition piece in forged quality
- Loose renewable disc and seat with conic metal-to-metal seal
- Stuffing box insert easy replaceable by bellows seal element

## Dimensions

| PN 400        | Size / DN | 8   |
|---------------|-----------|-----|
|               | L         | 567 |
|               | H         | 177 |
|               | D         | -   |
|               | A         | 185 |
| Weight ( kg ) | 9         |     |

## Pressure-Temperature-Rating

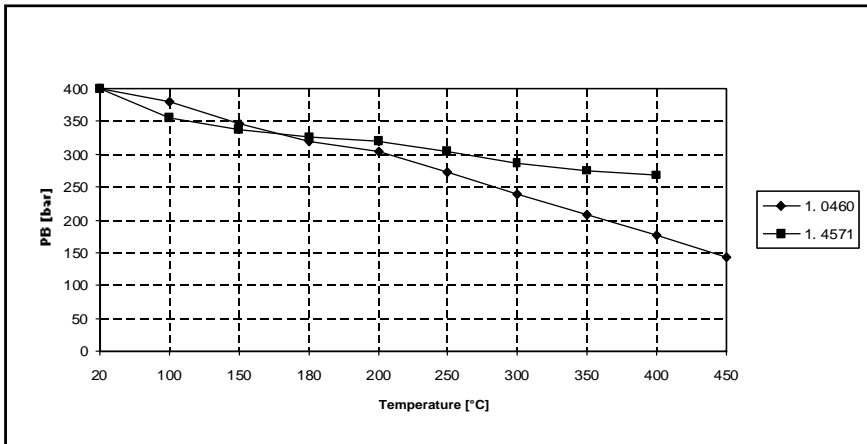

DN 8  
PN 400

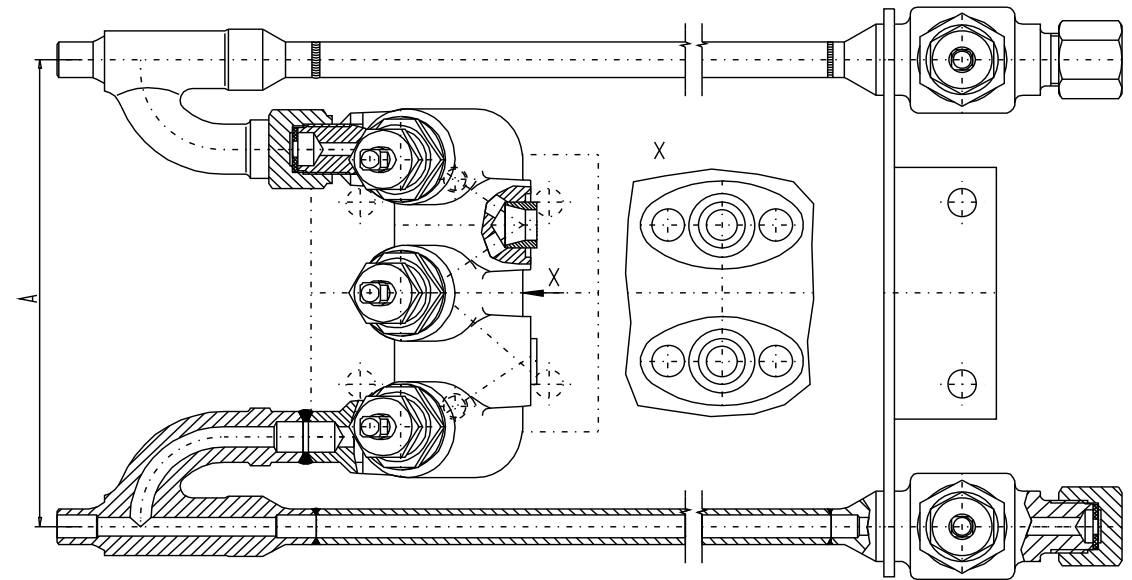
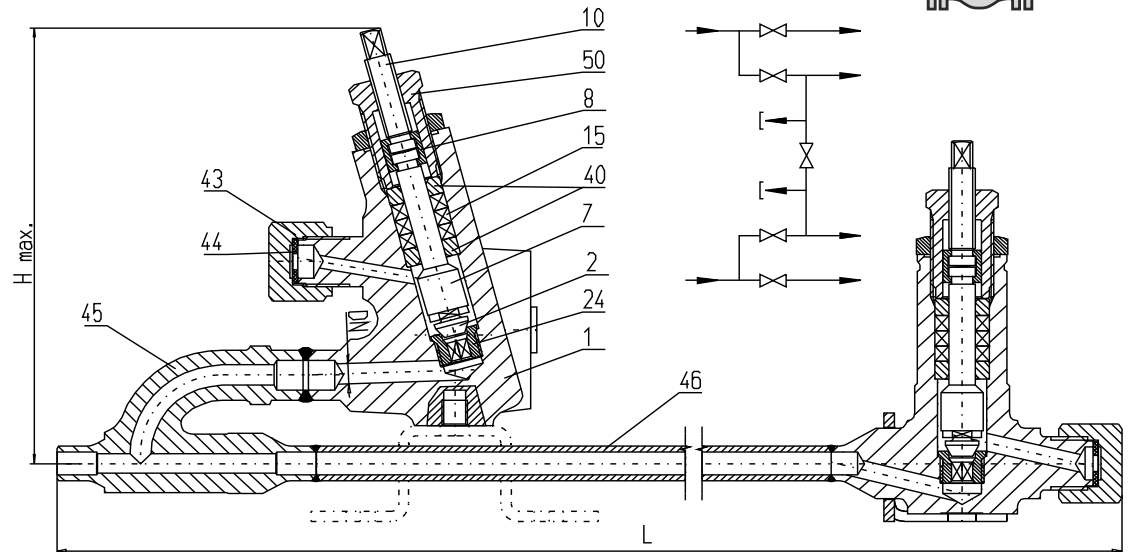

PHÖNIX reserves the right to change product design and specification without notice.

PHÖNIX • P +49 5693 988-0 • F +49 5693 988-178 • info@phoenix-valvegroup.com • https://phoenix-valvegroup.com

# Valve combination - 5fold / Type 630

PN 400 DN 8

## Materials

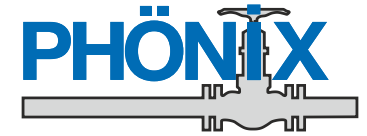

| Item | Part name        | Heat resistant carbon steel / Type 630 C |        | Stainless steel / Type 630 V     |        |
|------|------------------|--|--------|----------------------------------|--------|
|      |                  | Material up to 400°C                     | DIN    | Material from -270°C up to 400°C | DIN    |
| 1    | Body             | P250GH                                   | 1.0460 | X 6CrNiMoTi17-12-2               | 1.4571 |
| 2    | Disc             | X20Cr13                                  | 1.4021 | Colmonoy 4                       |        |
| 7    | Lower Stem       | X 6CrNiMoTi17-12-2                       | 1.4571 | X 6CrNiMoTi17-12-2               | 1.4571 |
| 15   | Packing          | Pure graphite                            |        | Pure graphite                    |        |
| 24   | Seat             | X 6CrNiMoTi17-12-2                       | 1.4571 | X 6CrNiMoTi17-12-2               | 1.4571 |
| 40   | Wiper            | X 6CrNiMoTi17-12-2                       | 1.4571 | X 6CrNiMoTi17-12-2               | 1.4571 |
| 41   | Pressure nut     | X 6CrNiMoTi17-12-2                       | 1.4571 | X 6CrNiMoTi17-12-2               | 1.4571 |
| 43   | Cap              | X5CrNi18-10                              | 1.4301 | X5CrNi18-10                      | 1.4301 |
| 44   | Gasket           |  | 2.4060 |                                  | 2.4060 |
| 45   | Transition piece | P250GH                                   | 1.0460 | X 6CrNiMoTi17-12-2               | 1.4571 |
| 46   | Pipe             | 16Mo3                                    | 1.5415 | X 6CrNiMoTi17-12-2               | 1.4571 |

Special materials on request.

## Specification

Marking EN19, AD-A4

Standard connections  
 Inlet: Butt weld ends for pipe with outside diameter from 12-24mm (Centre to centre distance: 155mm)  
 Outlet: Directly flanged to transducer (Centre to centre distance: 54mm)  
 Test: Nozzle M20x1,5 with cap  
 Drain: Male plug G1/2" with cap

Testing standard AD-2000, DIN 3230 section 3, DIN EN 12266

PHÖNIX reserves the right to change product design and specification without notice.

PHÖNIX • P +49 5693 988-0 • F +49 5693 988-178 • info@phoenix-valvegroup.com • https://phoenix-valvegroup.com

# Contact us

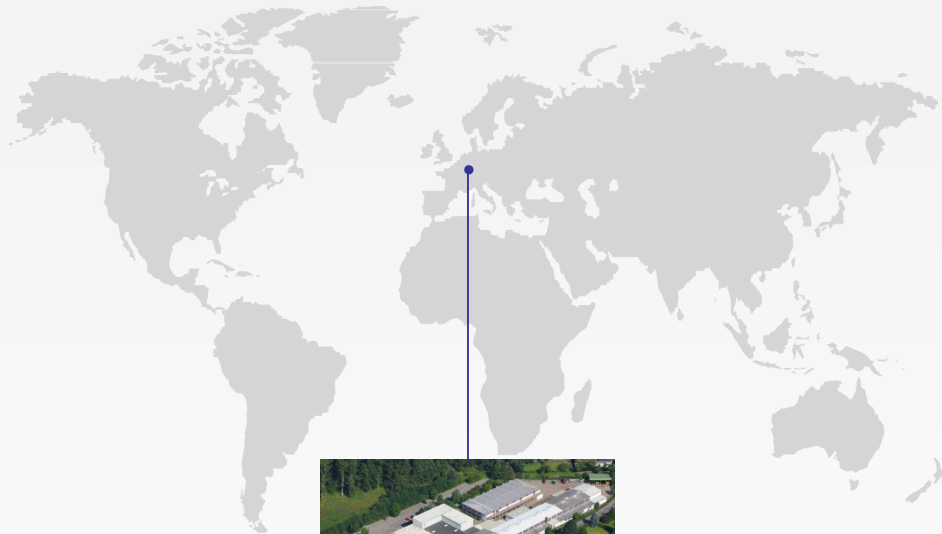

Volkmarsen, Germany

## Sales and Operations

### Phönix Valve Group GmbH

Volkmarsen, Germany  
Phone: +49 5693 988 0  
Email: [info@phoenix-valvegroup.com](mailto:info@phoenix-valvegroup.com)  
Website: [www.phoenix-valvegroup.com](http://www.phoenix-valvegroup.com)

### Phönix Armaturen Werke-Bregel GmbH

Volkmarsen, Germany  
Phone: +49 5693 988 0  
Email: [info@phoenix-valvegroup.com](mailto:info@phoenix-valvegroup.com)  
Website: [www.phoenix-valvegroup.com](http://www.phoenix-valvegroup.com)

### Strack GmbH

Volkmarsen, Germany  
Phone: +49 5693 988 0  
Email: [info@phoenix-valvegroup.com](mailto:info@phoenix-valvegroup.com)  
Website: [www.phoenix-valvegroup.com](http://www.phoenix-valvegroup.com)

### PAW SARL

Genay Cedex, France  
Phone: +33 437 408 195  
Email: [commercial@phoenix-valvegroup.com](mailto:commercial@phoenix-valvegroup.com)  
Website: [www.phoenix-valvegroup.com](http://www.phoenix-valvegroup.com)

### Daume Regelarmaturen GmbH

Volkmarsen, Germany  
Phone: +49 5693 988 0  
Email: [info@phoenix-valvegroup.com](mailto:info@phoenix-valvegroup.com)  
Website: [www.phoenix-valvegroup.com](http://www.phoenix-valvegroup.com)

### Solent & Pratt Phönix Ltd.

Volkmarsen, Germany  
Phone: +49 5693 988 0  
Email: [info@phoenix-valvegroup.com](mailto:info@phoenix-valvegroup.com)  
Website: [www.phoenix-valvegroup.com](http://www.phoenix-valvegroup.com)



While this information is presented in good faith and believed to be accurate, Phönix Valve Group GmbH, does not guarantee satisfactory results from reliance on such information. Nothing contained herein is to be construed as a warranty or guarantee, expressed or implied, regarding the performance, merchantability, fitness or any other matter with respect to the products, nor as a recommendation to use any product or process in conflict with any patent. Phönix Valve Group GmbH, reserves the right, without notice, to alter or improve the designs or specifications of the products described herein.

© 2022 Phönix Valve Group. All rights reserved. Specifications are subject to change without notice. All trademarks are property of their respective owners

Printed in Germany  
09/22-R0