



PHÖNIX

STRACK

DAUME
REGELARMATUREN



Solent & Pratt
Phönix Ltd

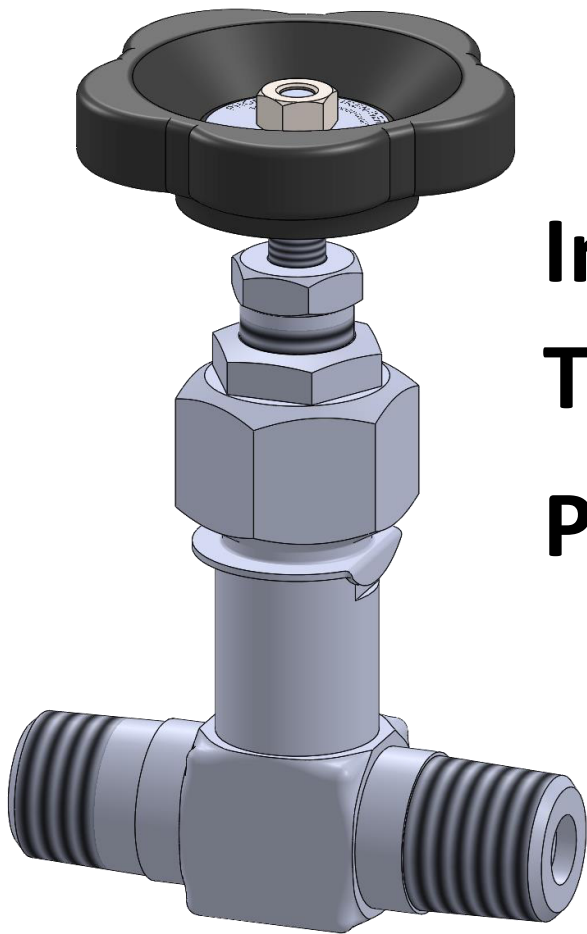

Instrumentation Valve Type 662 PN 100

Phönix Valve Group
Am Stadtbruch 6
34471 Volkmarsen

Phone:
web:
eMail:

+49 5693 988 0
www.phoenix-valvegroup.com
info@phoenix-valvegroup.com



Instrumentation valve / Type 662

DN 8
PN 100

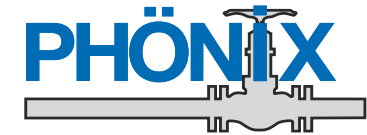

Design

- Isolating valve, thru way type, forged body
- Bellows, encapsulated, protected against erosion and abrasion by media flow
- Multiple wall bellows
- Designed up to 5000 operations
- Additional back seat at fully opened valve
- Additional emergency stuffing box
- Coupled divided stem with outside thread, rising handwheel
- Loose rolled-in disc with conic metal-to-metal seal

Dimensions

PN 100	Size / DN	8
	L	80
	H	110
	D	63
	Weight (kg)	0,5

Pressure-Temperature-Rating

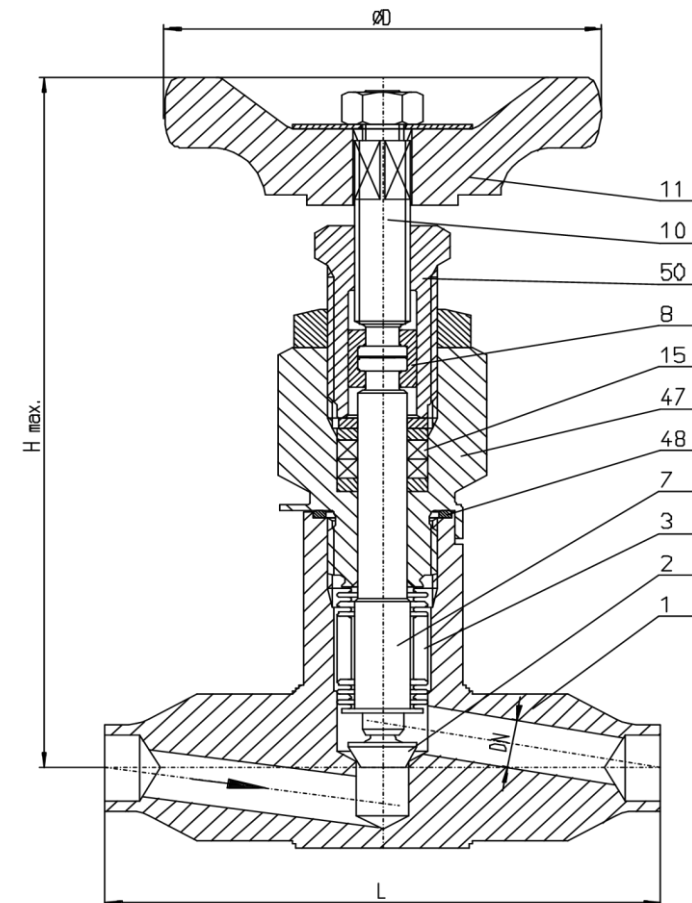
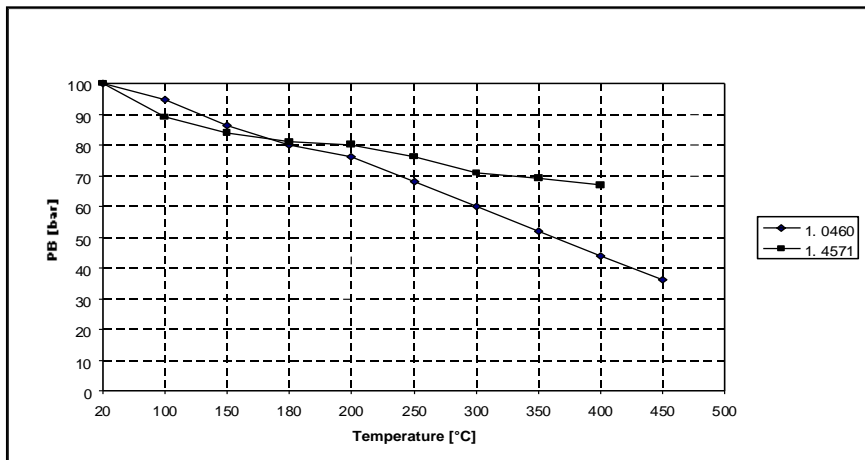

PHÖNIX reserves the right to change product design and specification without notice.

PHÖNIX • P +49 5693 988-0 • F +49 5693 988-178 • info@phoenix-valvegroup.com • https://phoenix-valvegroup.com

Instrumentation valve / Type 662

PN 100 DN 8

Materials



Item	Part name	Heat resistant carbon steel / Type 662 C		Stainless steel / Type 662 V	
		Material up to 400°C	DIN	Material from -270°C up to 400°C	DIN
1	Body	P250GH	1.0460	X 6CrNiMoTi17-12-2	1.4571
2	Disc	Stellite 6		Stellite 6	
3	Bellows	X 6CrNiMoTi17-12-2	1.4571	X 6CrNiMoTi17-12-2	1.4571
7	Lower Stem	X 6CrNiMoTi17-12-2	1.4571	X 6CrNiMoTi17-12-2	1.4571
8	Coupling	G-X 5 CrNiNb 18 9	1.4552	G-X 5 CrNiNb 18 9	1.4552
10	Upper Stem	X17CrNi16-2	1.4057	X17CrNi16-2	1.4057
11	Handwheel	Plastic		Plastic	
15	Packing	Pure Graphite		Pure Graphite	
47	Stem guide	X 6CrNiMoTi17-12-2	1.4571	X 6CrNiMoTi17-12-2	1.4571
48	Gasket, crowned	X 6CrNiMoTi17-12-2	1.4571	X 6CrNiMoTi17-12-2	1.4571
50	Stem nut	X 6CrNiMoTi17-12-2	1.4571	X 6CrNiMoTi17-12-2	1.4571

Special materials on request.

Specification

Marking	EN19, AD-A4
Standard connections	Butt weld ends for pipe with outside diameter up to 23mm
Testing standard	AD-2000, DIN 3230 section 3, DIN EN 12266

PHÖNIX reserves the right to change product design and specification without notice.

PHÖNIX • P +49 5693 988-0 • F +49 5693 988-178 • info@phoenix-valvegroup.com • https://phoenix-valvegroup.com

Contact us

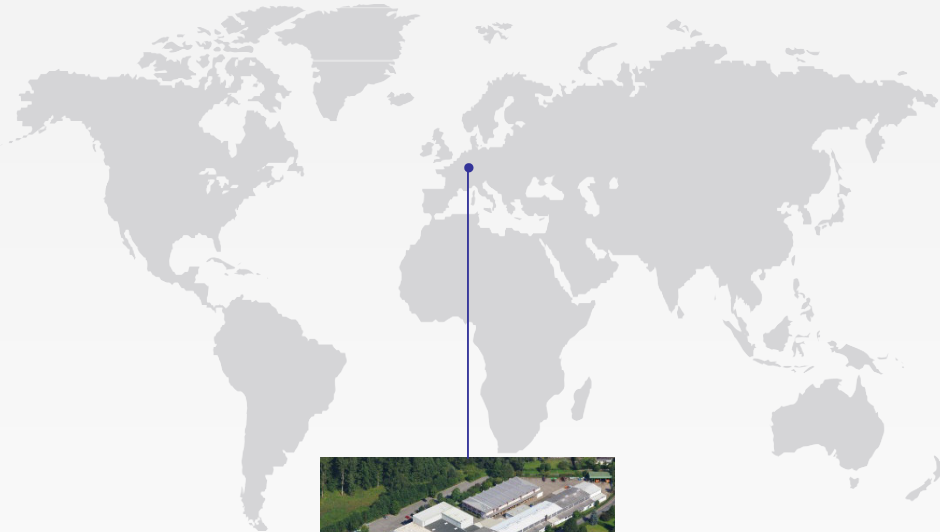

Volkmarsen, Germany

Sales and Operations

Phönix Valve Group GmbH

Volkmarsen, Germany
Phone: +49 5693 988 0
Email: info@phoenix-valvegroup.com
Website: www.phoenix-valvegroup.com

Phönix Armaturen Werke-Bregel GmbH

Volkmarsen, Germany
Phone: +49 5693 988 0
Email: info@phoenix-valvegroup.com
Website: www.phoenix-valvegroup.com

Strack GmbH

Volkmarsen, Germany
Phone: +49 5693 988 0
Email: info@phoenix-valvegroup.com
Website: www.phoenix-valvegroup.com

PAW SARL

Genay Cedex, France
Phone: +33 437 408 195
Email: commercial@phoenix-valvegroup.com
Website: www.phoenix-valvegroup.com

Daume Regelarmaturen GmbH

Volkmarsen, Germany
Phone: +49 5693 988 0
Email: info@phoenix-valvegroup.com
Website: www.phoenix-valvegroup.com

Solent & Pratt Phönix Ltd.

Volkmarsen, Germany
Phone: +49 5693 988 0
Email: info@phoenix-valvegroup.com
Website: www.phoenix-valvegroup.com



While this information is presented in good faith and believed to be accurate, Phönix Valve Group GmbH, does not guarantee satisfactory results from reliance on such information. Nothing contained herein is to be construed as a warranty or guarantee, expressed or implied, regarding the performance, merchantability, fitness or any other matter with respect to the products, nor as a recommendation to use any product or process in conflict with any patent. Phönix Valve Group GmbH, reserves the right, without notice, to alter or improve the designs or specifications of the products described herein.

© 2022 Phönix Valve Group. All rights reserved. Specifications are subject to change without notice. All trademarks are property of their respective owners

Printed in Germany
09/22-R0