



PHÖNIX

STRACK

DAUME
REGELARMATUREN



Solent & Pratt
Phoenix Ltd

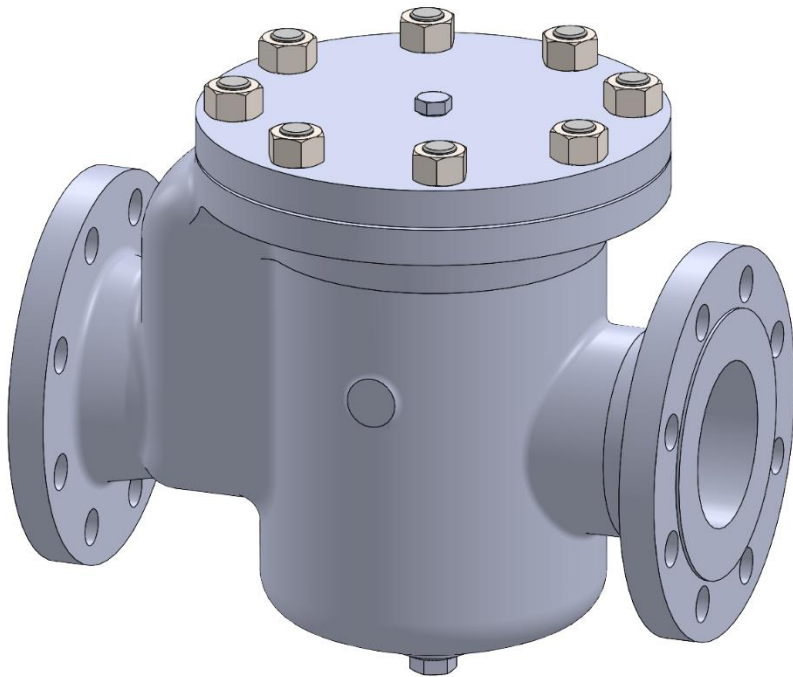

Strainer

Type 820

Class 150

Phoenix Valve Group
Am Stadtbruch 6
34471 Volkmarsen

Phone:
web:
eMail:

+49 5693 988 0
www.phoenix-valvegroup.com
info@phoenix-valvegroup.com



Strainer basket type / Type 820

Class 150 NPS ½ - 10

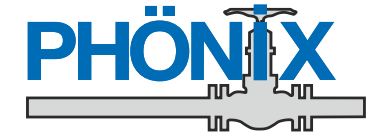

Design

- Inserts totally of stainless steel
- Easy replaceable basket inserts
- Extremely huge filtrating area

CE 0525

Filter net acc. to DIN ISO 4783, Standard:

576 Meshes/cm², i.e.

Mesh width = 0,25mm

Dimensions

Cl. 150	NPS	½	¾	1	1¼	1½	2	2½	3	4	5	6	8	10
	L	160	180	195	230	260	330	340	390	410	500	530	630	865
	H1	85	95	90	110	115	150	120	190	215	270	285	350	465
	H2	95	100	105	120	120	155	160	165	165	215	220	360	435
	D	105	125	125	170	190	230	230	265	280	350	350	420	580
	Weight (kg)	4	7	9	15	19	27	35	50	57	100	122	260	390

Drag coefficient / Flow coefficient

NPS	½	¾	1	1¼	1½	2	2½	3	4	5	6	8	10
ζ _v [-]	3,5	2,5	5,1	4,1	3,1	4,4	4,7	5	7,5	7,9	8	5,9	5,8
k _v [m ³ /h]	4,8	10	11	20	36	47	77	113	145	220	260	650	850
c _v [USgal/min]	5,6	11,6	13	23	42	55	90	131	169	256	302	756	988

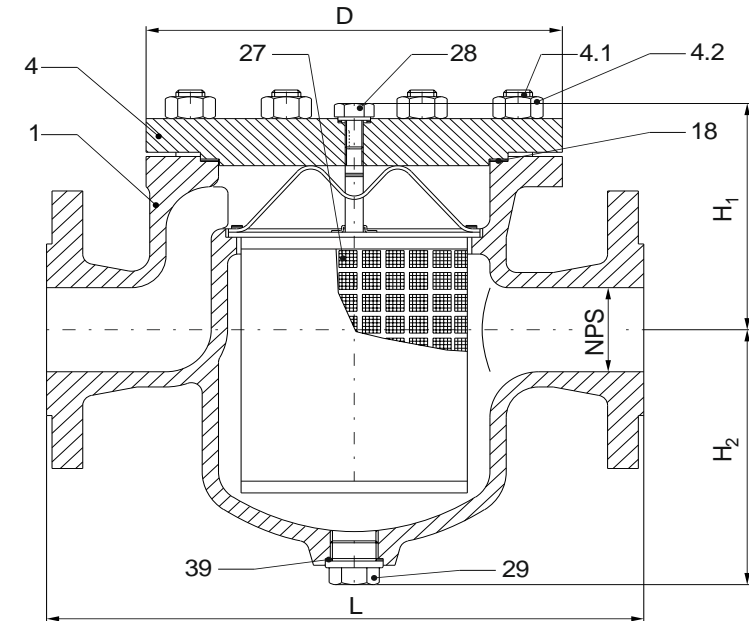

PHÖNIX reserves the right to change product design and specification without notice.

Strainer basket type / Type 820

Class 150 NPS ½ - 10



Materials

Item	Part name	Heat resistant carbon steel / Type 820 C	Stainless steel / Type 820 V
		Material up to 450°C	Material from -200°C up to 400°C
1	Body	A 105 A 216 WCB	A 182 Gr.F316L A 351 CF 8M
4	Bonnet	A 105	A 479 Gr.316L
4.1	Stud bolt	-	A 193 Gr. B8
4.2	Hex.nut	A 194 Gr. 7L	A 194 Gr. 8
18	Bonnet gasket	Graphite + S.S.	Graphite + S.S.
27	Strainer	A 479 Gr.316Ti A 182 Gr.F316	A 479 Gr.316Ti
28	Vent srew	A 479 Gr.316Ti	A 479 Gr.316Ti
29	Drain screw	A 479 Gr.316Ti	A 479 Gr.316Ti
39	Gasket for drain screw	1.1003	1.1003

Special materials on request.

Specification

Marking	MSS SP-25, ISO 5209 (EN19, AD-A4, CE)
Face-to-face dimensions	
Flanged option	Manufacturer standard
Butt weld ends	Manufacturer standard
Socket weld ends	Manufacturer standard
Connections	
Flanged option	ASME B 16.5
Butt weld ends	ASME B 16.25
Socket weld ends	ASME B 16.11
Pressure-temp.-rating	ASME B 16.34
Testing standard	API 598, ISO 5208 (AD-2000, DIN 3230 section 3)

PHÖNIX reserves the right to change product design and specification without notice.

PHÖNIX • P +49 5693 988-0 • F +49 5693 988-178 • info@phoenix-valvegroup.com • https://phoenix-valvegroup.com

Contact us



Volkmarsen, Germany

Sales and Operations

Phönix Valve Group GmbH

Volkmarsen, Germany
Phone: +49 5693 988 0
Email: info@phoenix-valvegroup.com
Website: www.phoenix-valvegroup.com

Phönix Armaturen Werke-Bregel GmbH

Volkmarsen, Germany
Phone: +49 5693 988 0
Email: info@phoenix-valvegroup.com
Website: www.phoenix-valvegroup.com

Strack GmbH

Volkmarsen, Germany
Phone: +49 5693 988 0
Email: info@phoenix-valvegroup.com
Website: www.phoenix-valvegroup.com

PAW SARL

Genay Cedex, France
Phone: +33 437 408 195
Email: commercial@phoenix-valvegroup.com
Website: www.phoenix-valvegroup.com

Daume Regelarmaturen GmbH

Volkmarsen, Germany
Phone: +49 5693 988 0
Email: info@phoenix-valvegroup.com
Website: www.phoenix-valvegroup.com

Solent & Pratt Phönix Ltd.

Volkmarsen, Germany
Phone: +49 5693 988 0
Email: info@phoenix-valvegroup.com
Website: www.phoenix-valvegroup.com



While this information is presented in good faith and believed to be accurate, Phönix Valve Group GmbH, does not guarantee satisfactory results from reliance on such information. Nothing contained herein is to be construed as a warranty or guarantee, expressed or implied, regarding the performance, merchantability, fitness or any other matter with respect to the products, nor as a recommendation to use any product or process in conflict with any patent. Phönix Valve Group GmbH, reserves the right, without notice, to alter or improve the designs or specifications of the products described herein.

© 2022 Phönix Valve Group. All rights reserved. Specifications are subject to change without notice. All trademarks are property of their respective owners

Printed in Germany
09/22-R0