



PHÖNIX

STRACK

DAUME
REGELARMATUREN



Solent & Pratt
Phoenix Ltd

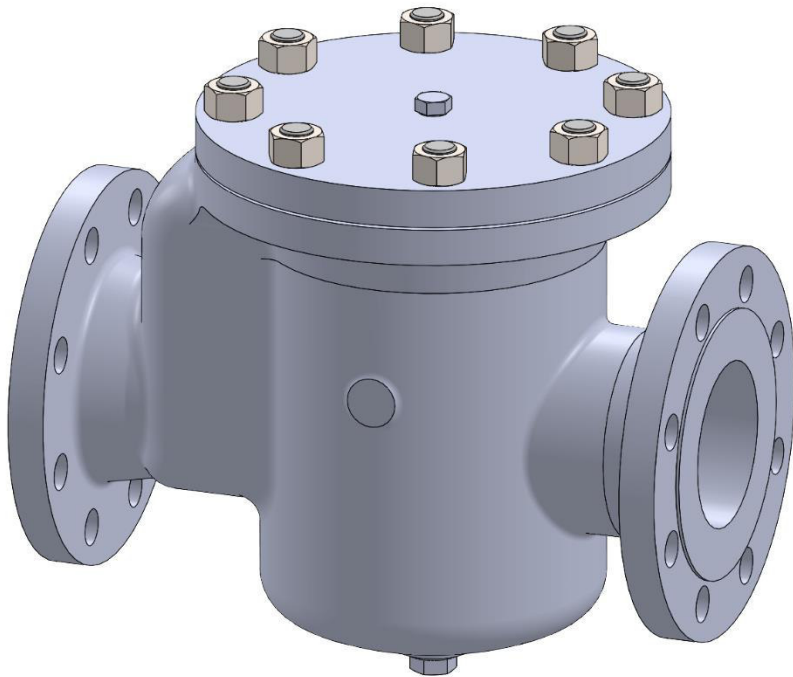

Strainer Type 820 PN 63

Phönix Valve Group
Am Stadtbruch 6
34471 Volkmarsen

Phone:
web:
eMail:

+49 5693 988 0
www.phoenix-valvegroup.com
info@phoenix-valvegroup.com



Strainer basket type / Type 820

PN63 DN15-DN250

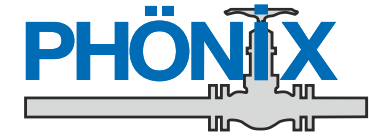

Design

Inserts totally of stainless steel
Easy replaceable basket inserts
Extremely huge filtrating area

Filter net acc. to DIN ISO 4783, Standard:

576 Meshes/cm², i.e.

Mesh width = 0,25mm

CE 0525

Dimensions

PN 63	Size / DN	15	20	25	32	40	50	65	80	100	125	150	200	250
	L	180	200	215	250	280	355	365	420	440	530	565	670	910
H1	100	110	115	125	135	170	180	210	235	290	315	390	495	
H2	105	110	115	130	130	165	165	170	170	225	230	365	450	
D	105	125	125	170	190	230	230	265	280	350	350	420	580	
Weight (kg)	6,5	11	14	24	28	40	52	68	85	130	195	338	515	

Drag coefficient / Flow coefficient

Size / DN	15	20	25	32	40	50	65	80	100	125	150	200	250
$\zeta_v [-]$	3,5	2,5	5,1	4,1	3,1	4,4	4,7	5	7,5	7,9	8	5,9	5,8
$k_v [m^3/h]$	4,8	10	11	20	36	47	77	113	145	220	260	650	850

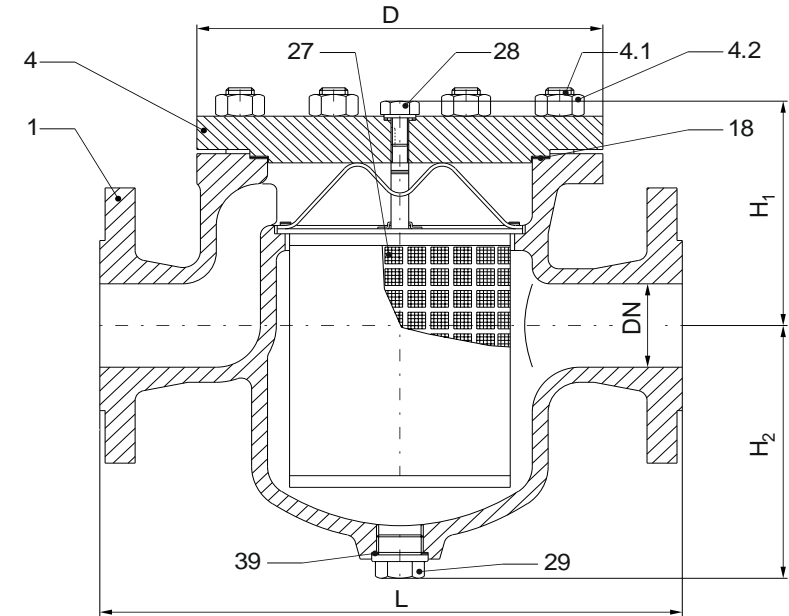

PHÖNIX reserves the right to change product design and specification without notice.

Strainer basket type / Type 820

PN16/ 25/ 40/ 63 DN15 - DN400

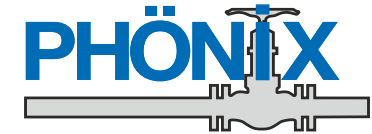

Materials

Item	Part name	Heat resistant carbon steel / Type 820 C		Stainless steel / Type 820 V	
		Material * up to 450°C	DIN	Material * from -200°C up to 400°C	DIN
1	Body	P250GH	1.0460	X2CrNiMo17-12-2	1.4404
		GP240GH	1.0619	GX5CrNiMo19-11-2	1.4408
4	Bonnet	P250GH	1.0460	X2CrNiMo17-12-2	1.4404
4.1	Stud bolt	21CrMoV5-7	1.7709	A4-70	
4.2	Hex.nut	25CrMo4	1.7218	A4-70	
18	Bonnet gasket	Stainless steel / graphite		Stainless steel / graphite	
27	Strainer	X6CrNiMoTi17-12-2	1.4571	X6CrNiMoTi17-12-2	1.4571
		X5CrNiMo17-12-2	1.4401		
28	Vent srew	X6CrNiMoTi17-12-2	1.4571	X6CrNiMoTi17-12-2	1.4571
29	Drain screw	X6CrNiMoTi17-12-2	1.4571	X6CrNiMoTi17-12-2	1.4571
39	Gasket for drain screw		1.1003		1.1003

Special materials on request.

* Pressure-Temperature-Rating see appendix

Specification

Marking	EN19, AD-A4, CE
Face-to-face dimensions	
Flanged option	Manufacturer standard
Butt weld ends	Manufacturer standard
Socket weld ends	Manufacturer standard
Connections	
Flanged option	DIN EN 1092-1 up to PN100
Butt weld ends	DIN EN 12627
Socket weld ends	DIN EN 12760
Testing standard	AD-2000, DIN 3230 section 3, DIN EN 12266

PHÖNIX reserves the right to change product design and specification without notice.

PHÖNIX • P +49 5693 988-0 • F +49 5693 988-178 • info@phoenix-valvegroup.com • <https://phoenix-valvegroup.com>

Contact us

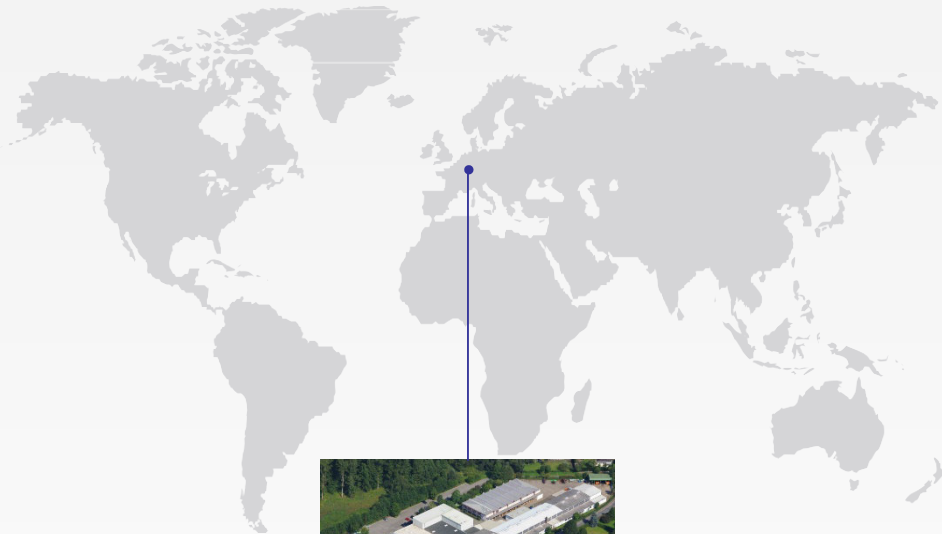

Volkmarsen, Germany

Sales and Operations

Phönix Valve Group GmbH

Volkmarsen, Germany
Phone: +49 5693 988 0
Email: info@phoenix-valvegroup.com
Website: www.phoenix-valvegroup.com

Phönix Armaturen Werke-Bregel GmbH

Volkmarsen, Germany
Phone: +49 5693 988 0
Email: info@phoenix-valvegroup.com
Website: www.phoenix-valvegroup.com

Strack GmbH

Volkmarsen, Germany
Phone: +49 5693 988 0
Email: info@phoenix-valvegroup.com
Website: www.phoenix-valvegroup.com

PAW SARL

Genay Cedex, France
Phone: +33 437 408 195
Email: commercial@phoenix-valvegroup.com
Website: www.phoenix-valvegroup.com

Daume Regelarmaturen GmbH

Volkmarsen, Germany
Phone: +49 5693 988 0
Email: info@phoenix-valvegroup.com
Website: www.phoenix-valvegroup.com

Solent & Pratt Phönix Ltd.

Volkmarsen, Germany
Phone: +49 5693 988 0
Email: info@phoenix-valvegroup.com
Website: www.phoenix-valvegroup.com



While this information is presented in good faith and believed to be accurate, Phönix Valve Group GmbH, does not guarantee satisfactory results from reliance on such information. Nothing contained herein is to be construed as a warranty or guarantee, expressed or implied, regarding the performance, merchantability, fitness or any other matter with respect to the products, nor as a recommendation to use any product or process in conflict with any patent. Phönix Valve Group GmbH, reserves the right, without notice, to alter or improve the designs or specifications of the products described herein.

© 2022 Phönix Valve Group. All rights reserved. Specifications are subject to change without notice. All trademarks are property of their respective owners

Printed in Germany
09/22-R0