



PHÖNIX

STRACK

DAUME
REGELARMATUREN



Solent & Pratt
Phoenix Ltd

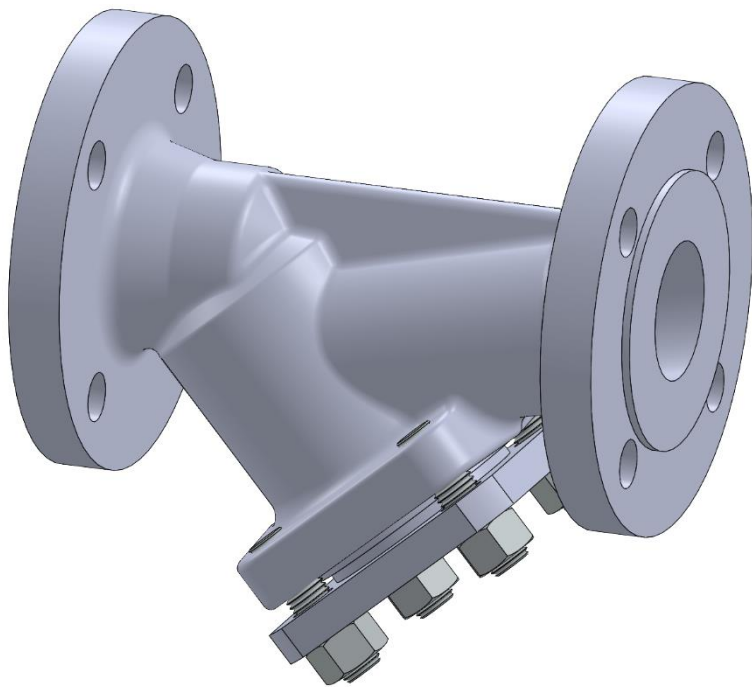

Strainer

Type 829

Class 150

Phönix Valve Group
Am Stadtbruch 6
34471 Volkmarsen

Phone:
web:
eMail:

+49 5693 988 0
www.phoenix-valvegroup.com
info@phoenix-valvegroup.com



Strainer Y - type / Type 829

Class 150 / 300 / 600 NPS 1/2 - 6



CE 0525

Design

- Inclined seat for optimized fluid flow
- Inserts from high-alloyed steel
- Easy replaceable basket
- Extremely high filtrating area

Filter net acc. to DIN ISO 4783, Standard:	up to NPS 2	= 0,8mm
	NPS 2½ / 3	= 1,0mm
	NPS 4 / 6	= 1,25mm

Dimensions

Cl. 150	NPS	1/2	3/4	1	1 1/4	1 1/2	2	2 1/2	3	4	5	6
	L	140	152	165	184	203	229	279	318	368	on request	470
	H1	95	90	90	90	125	135	165	195	240		315
	H2	150	140	140	150	190	220	250	300	350		470
	D	32	32	32	38	53	60	80	95	115		165
	Weight (kg)	3,6	4	4,5	10	12	15	20	28	40		92

Drag coefficient / Flow coefficient

NPS	1/2	3/4	1	1 1/4	1 1/2	2	2 1/2	3	4	5	6
$\zeta_v [-]$	5,1	3,8	6,6	3,8	6,7	7,5	5,5	3,9	3,6	4,4	3,6
$k_v [m^3/h]$	4,4	9	11	23	27	40	98	142	225	322	510
$c_v [USgal/min]$	5,1	10	13	27	31	47	114	165	262	374	593

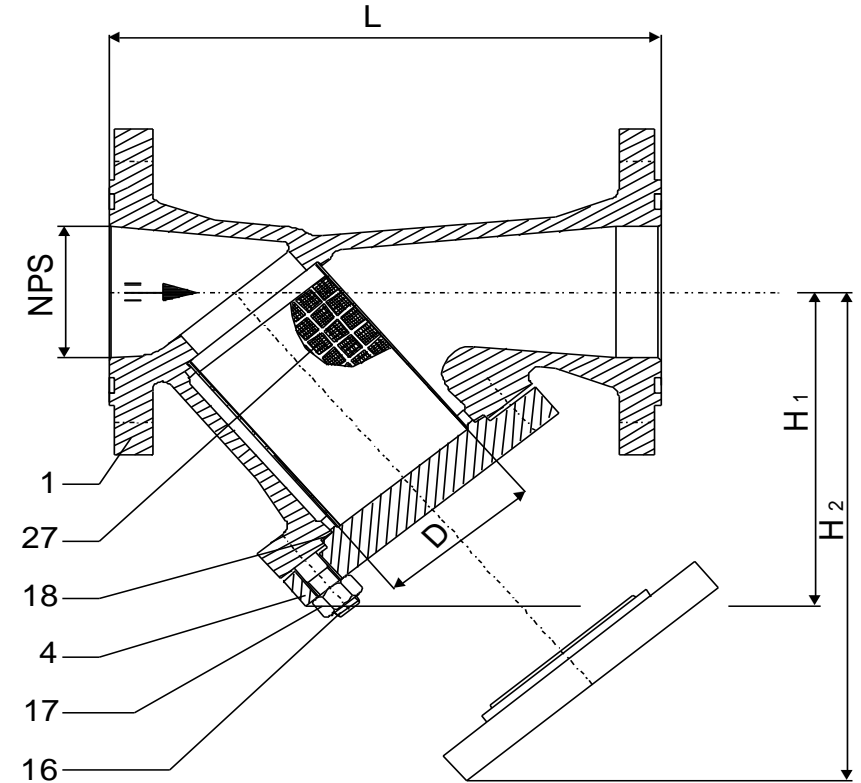

Strainer Y - type / Type 829

Class 150 / 300 / 600 NPS ½ - 6

Materials



Item	Part name	Heat resistant carbon steel / Type 829 C	Stainless steel / Type 829 V
		Material up to 450°C	Material from -200°C up to 400°C
1	Body	A 105 A 216 WCB	A 182 Gr.F316L A 351 CF 8M
4	Bonnet	A 105	A 479 Gr.316L
16	Stud bolt	A 193 Gr.B7	A 193 Gr. B8
17	Hex.nut	A 194 Gr. 7L	A 194 Gr. 8
18	Bonnet gasket	Graphite + S.S.	Graphite + S.S.
27	Strainer	A 479 Gr.316Ti A182 G. F316	A 479 Gr.316Ti

Special materials on request.

Specification

Marking	MSS SP-25, ISO 5209 (EN19, AD-A4, CE)
Face-to-face dimensions	
Flanged option	ASME B 16.10
Butt weld ends	ASME B 16.10
Socket weld ends	ASME B 16.34
Connections	
Flanged option	ASME B 16.5
Butt weld ends	ASME B 16.25
Socket weld ends	ASME B 16.11
Pressure-temp.-rating	ASME B 16.34
Testing standard	API 598, ISO 5208 (AD-2000, DIN 3230 section 3)

PHÖNIX reserves the right to change product design and specification without notice.

PHÖNIX • P +49 5693 988-0 • F +49 5693 988-178 • info@phoenix-valvegroup.com • https://phoenix-valvegroup.com

Contact us

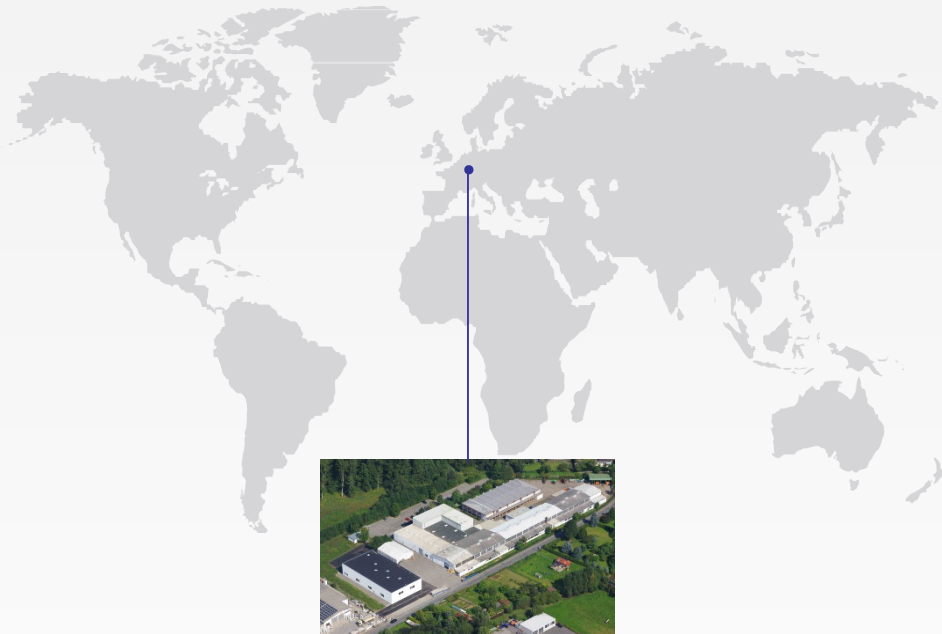

Volkmarsen, Germany

Sales and Operations

Phönix Valve Group GmbH

Volkmarsen, Germany
Phone: +49 5693 988 0
Email: info@phoenix-valvegroup.com
Website: www.phoenix-valvegroup.com

Phönix Armaturen Werke-Bregel GmbH

Volkmarsen, Germany
Phone: +49 5693 988 0
Email: info@phoenix-valvegroup.com
Website: www.phoenix-valvegroup.com

Strack GmbH

Volkmarsen, Germany
Phone: +49 5693 988 0
Email: info@phoenix-valvegroup.com
Website: www.phoenix-valvegroup.com

PAW SARL

Genay Cedex, France
Phone: +33 437 408 195
Email: commercial@phoenix-valvegroup.com
Website: www.phoenix-valvegroup.com

Daume Regelarmaturen GmbH

Volkmarsen, Germany
Phone: +49 5693 988 0
Email: info@phoenix-valvegroup.com
Website: www.phoenix-valvegroup.com

Solent & Pratt Phönix Ltd.

Volkmarsen, Germany
Phone: +49 5693 988 0
Email: info@phoenix-valvegroup.com
Website: www.phoenix-valvegroup.com



While this information is presented in good faith and believed to be accurate, Phönix Valve Group GmbH, does not guarantee satisfactory results from reliance on such information. Nothing contained herein is to be construed as a warranty or guarantee, expressed or implied, regarding the performance, merchantability, fitness or any other matter with respect to the products, nor as a recommendation to use any product or process in conflict with any patent. Phönix Valve Group GmbH, reserves the right, without notice, to alter or improve the designs or specifications of the products described herein.

© 2022 Phönix Valve Group. All rights reserved. Specifications are subject to change without notice. All trademarks are property of their respective owners

Printed in Germany
09/22-R0