



PHÖNIX

STRACK

DAUME
REGELARMATUREN



Solent & Pratt
Phönix Ltd

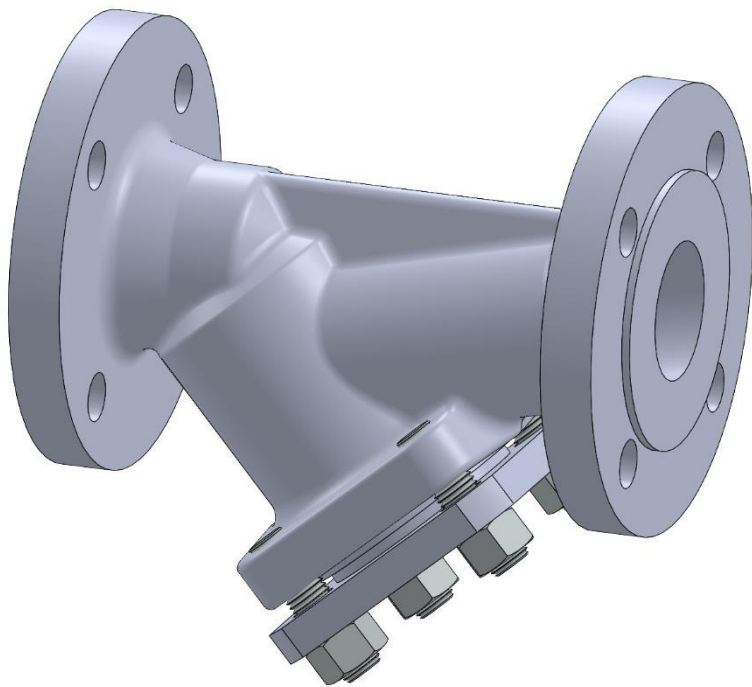

Strainer

Type 829

PN 16

Phönix Valve Group
Am Stadtbruch 6
34471 Volkmarsen

Phone:
web:
eMail:

+49 5693 988 0
www.phoenix-valvegroup.com
info@phoenix-valvegroup.com



Strainer Y - type / Type 829

PN16 DN15 - DN150



Design

Inclined seat for optimized fluid flow

Inserts from high-alloyed steel

Easy replaceable basket

Extremely high filtrating area

Filter net acc. to DIN ISO 4783, Standard:

up to DN 50	= 0,8mm
DN 65/80	= 1,0mm
DN 100/150	= 1,25mm

Dimensions

PN16	Size / DN	15	20	25	32	40	50	65	80	100	125	150
	L	130	150	160	180	200	230	290	310	350	400	480
H1	95	90	90	90	125	135	165	195	240	260	315	
H2	150	140	140	150	190	220	250	300	350	385	470	
D	32	32	32	38	53	60	80	95	115	140	165	
Weight (kg)	3,6	4	4,5	10	12	15	20	28	40	66	92	

Drag coefficient / Flow coefficient

Size / DN	15	20	25	32	40	50	65	80	100	125	150
$\zeta_v [-]$	5,1	3,8	6,6	3,8	6,7	7,5	5,5	3,9	3,6	4,4	3,6
$k_v [m^3/h]$	4,4	9	11	23	27	40	98	142	225	322	510

PHÖNIX reserves the right to change product design and specification without notice.

CE 0525

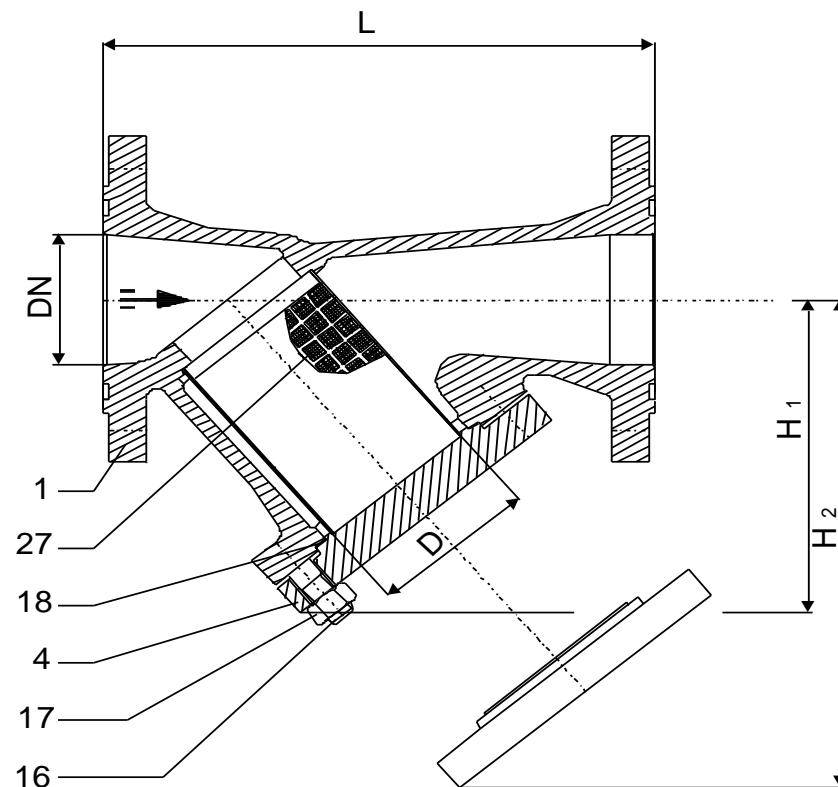

Strainer Y - type / Type 829

PN16/ 25/ 40 DN15 - DN150

Materials



Item	Part name	Heat resistant carbon steel / Type 829 C		Stainless steel / Type 829 V	
		Material * up to 450°C	DIN	Material * from -200°C up to 400°C	DIN
1	Body	P250GH	1.0460	X2CrNiMo17-12-2	1.4404
		GP240GH	1.0619	GX5CrNiMo19-11-2	1.4408
4	Bonnet	P250GH	1.0460	X2CrNiMo17-12-2	1.4404
16	Stud bolt	21CrMoV5-7	1.7709	A4-70	
17	Hex.nut	25CrMo4	1.7218	A4-70	
18	Bonnet gasket	Graphite + S.S.		Graphite + S.S.	
27	Strainer	X6CrNiMoTi17-12-2	1.4571	X6CrNiMoTi17-12-2	1.4571
		X5CrNiMo17-12-2	1.4401		

Special materials on request.

* Pressure-temperature-rating see appendix

Specification

Marking	EN19, AD-A4, CE
Face-to-face dimensions	
Flanged option	DIN EN 558-1
Butt weld ends	DIN EN 12982 up to PN100
Socket weld ends	
Connections	
Flanged option	DIN EN 1092-1 up to PN100
Butt weld ends	DIN EN 12627
Socket weld ends	DIN EN 12760
Testing standard	AD-2000, DIN 3230 section 3, DIN EN 12266

PHÖNIX reserves the right to change product design and specification without notice.

PHÖNIX • P +49 5693 988-0 • F +49 5693 988-178 • info@phoenix-valvegroup.com • https://phoenix-valvegroup.com

Contact us



Volkmarsen, Germany

Sales and Operations

Phönix Valve Group GmbH

Volkmarsen, Germany
Phone: +49 5693 988 0
Email: info@phoenix-valvegroup.com
Website: www.phoenix-valvegroup.com

Phönix Armaturen Werke-Bregel GmbH

Volkmarsen, Germany
Phone: +49 5693 988 0
Email: info@phoenix-valvegroup.com
Website: www.phoenix-valvegroup.com

Strack GmbH

Volkmarsen, Germany
Phone: +49 5693 988 0
Email: info@phoenix-valvegroup.com
Website: www.phoenix-valvegroup.com

PAW SARL

Genay Cedex, France
Phone: +33 437 408 195
Email: commercial@phoenix-valvegroup.com
Website: www.phoenix-valvegroup.com

Daume Regelarmaturen GmbH

Volkmarsen, Germany
Phone: +49 5693 988 0
Email: info@phoenix-valvegroup.com
Website: www.phoenix-valvegroup.com

Solent & Pratt Phönix Ltd.

Volkmarsen, Germany
Phone: +49 5693 988 0
Email: info@phoenix-valvegroup.com
Website: www.phoenix-valvegroup.com

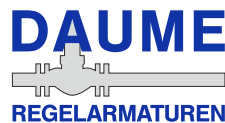

While this information is presented in good faith and believed to be accurate, Phönix Valve Group GmbH, does not guarantee satisfactory results from reliance on such information. Nothing contained herein is to be construed as a warranty or guarantee, expressed or implied, regarding the performance, merchantability, fitness or any other matter with respect to the products, nor as a recommendation to use any product or process in conflict with any patent. Phönix Valve Group GmbH, reserves the right, without notice, to alter or improve the designs or specifications of the products described herein.

© 2022 Phönix Valve Group. All rights reserved. Specifications are subject to change without notice. All trademarks are property of their respective owners

Printed in Germany
09/22-R0