



PHÖNIX

STRACK

DAUME
REGELARMATUREN



Solent & Pratt
Phönix Ltd

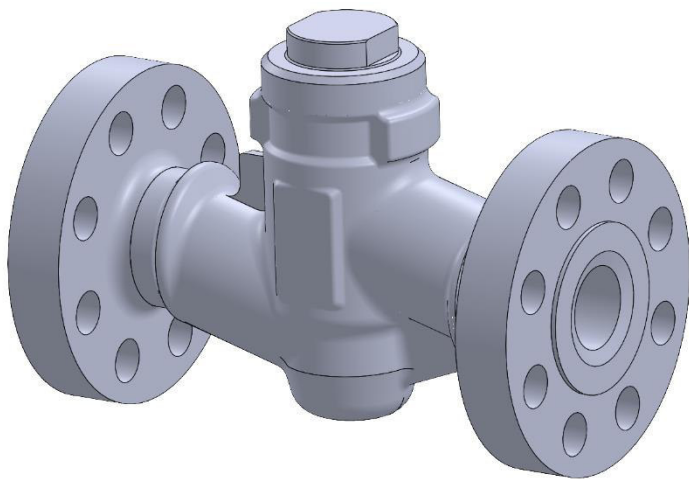

Check Valve

Type S27

PN 160 - 400

Phönix Valve Group
Am Stadtbruch 6
34471 Volkmarsen

Phone:
web:
eMail:

+49 5693 988 0
www.phoenix-valvegroup.com
info@phoenix-valvegroup.com



Piston Check Valve / Type S27

DN 15 - 50
PN160 / 250 / 400

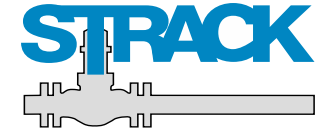

Design

- Replaceable disc with metal-to-metal seal
- Available with or without pressure spring
- Opening at a differential pressure of 0,05 bar
- Construction of forged components and coverless design

Dimensions - Flanged Valves

PN 160 - 400	Size / DN	15	25	40	50
	L PN 160	210	230	-	300
	L PN 250	230	260	300	350
	L PN 320	230	260	300	350
	L PN 400	260	300	350	400
	H	97	97	150	150
Weight PN 400 (kg)		14,5		50	

Drag coefficient / Flow coefficient

Size / DN	15	25	40	50
ζ_v [-]	on request			
k_v [m ³ /h]				

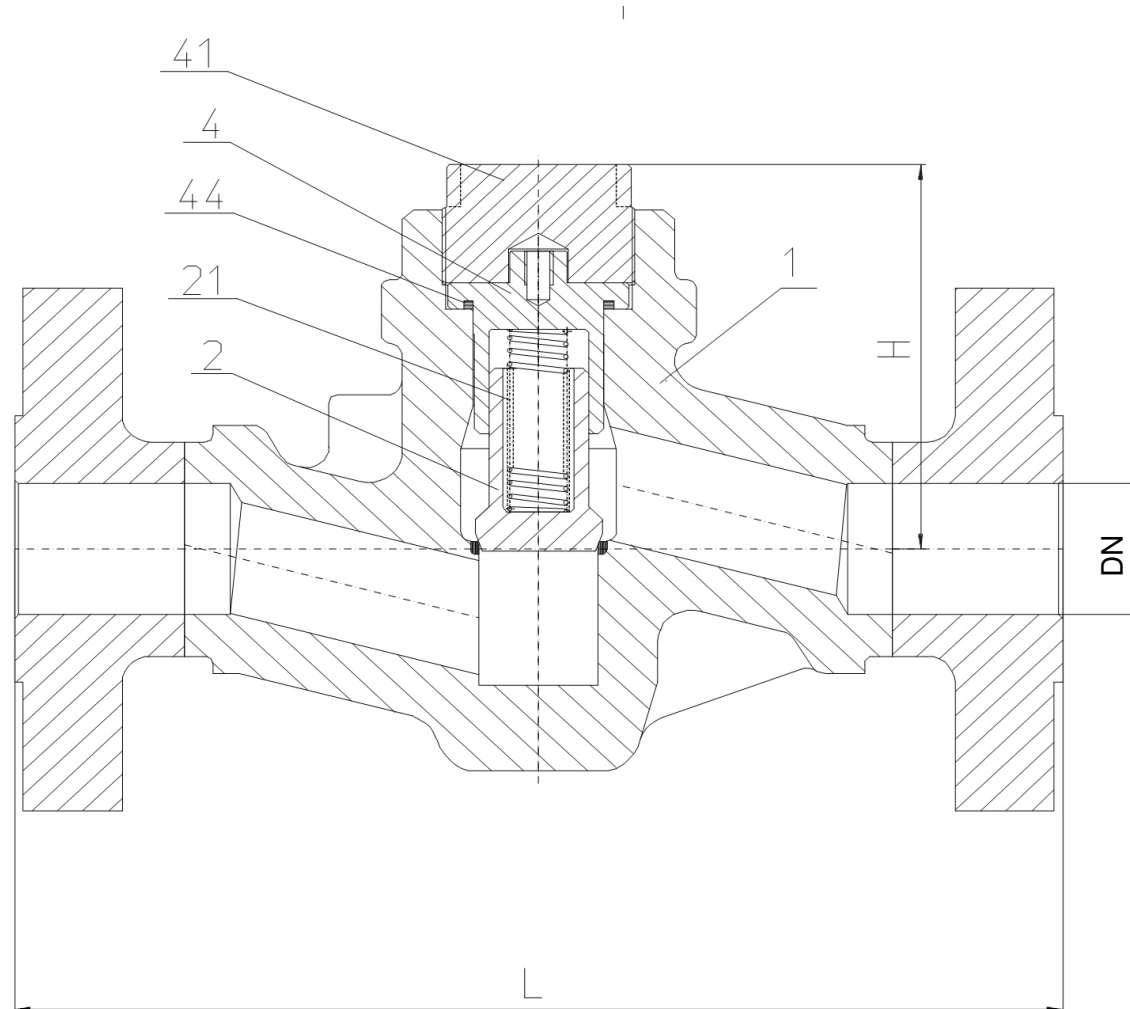

PHÖNIX reserves the right to change product design and specification without notice.

Piston Check Valve / Type S27

PN160 / 250 / 400 DN15 - DN50

Materials



Item	Part name	Heat resistant carbon steel			Low temperature steel		Stainless steel		
		Material *		DIN	Material * -50 °C / 500 bar 400 °C / 375 bar	DIN	Material * 20 °C / 500 bar 550 °C / 356 bar	DIN	
1	Body	20 °C / 630 bar ... 450 °C / 193 bar	P250GH	1.0460	P355NL1	1.0566	X 2CrNiMo17-12-2	1.4404	
		20 °C / 630 bar ... 530 °C / 132 bar	16Mo3	1.5415					
		20 °C / 630 bar ... 550 °C / 137 bar	13CrMo4-5	1.7335					
		20 °C / 630 bar ... 600 °C / 95 bar	10CrMo9-10	1.7380					
		20 °C / 630 bar ... 650 °C / 123 bar	X10CrMoVNb9	1.4903					
	Overlay	Stellite 21 (≈ 32 HRC)			Stellite 21 (≈ 32 HRC)		Stellite 21 (≈ 32 HRC)		
2	Disc	X39CrMo17-1			1.4122	X20CrMoV11-1	1.4922	X 6CrNiMoTi17-12-2	1.4571
	Overlay	-				Stellite 6 (≈ 42 HRC)		Stellite 6 (≈ 42 HRC)	
4	Bonnet	13CrMo4-5			1.7335	13CrMo4-5	1.0566	13CrMo4-5	1.4404
21	Spring	X10CrNi18-8			1.4310	X10CrNi18-8	1.4310	X10CrNi18-8	1.4310
41	Pressure bolt	X20CrMoV11-1			1.4922	X20CrMoV11-1	1.4922	X20CrMoV11-1	1.4922
44	Gasket	Graphite				Graphite		Graphite	

Special materials on request.

* Pressure-temperature-rating see appendix

Specification

Marking EN19, AD-A4, CE
 Face-to-face dimensions
 Flanged option Manufacturer standard

Connections
 Flanged option DIN EN 1092-1 (bis PN 100) / DIN 2638 (PN160) / DIN 2628 (PN 250) / DIN 2629 (PN320) / DIN 2627 (PN400)

Testing standard AD-2000, DIN 3230 section 3, DIN EN 12266

PHÖNIX reserves the right to change product design and specification without notice.

Contact us



Volkmarsen, Germany

Sales and Operations

Phönix Valve Group GmbH

Volkmarsen, Germany
Phone: +49 5693 988 0
Email: info@phoenix-valvegroup.com
Website: www.phoenix-valvegroup.com

Phönix Armaturen Werke-Bregel GmbH

Volkmarsen, Germany
Phone: +49 5693 988 0
Email: info@phoenix-valvegroup.com
Website: www.phoenix-valvegroup.com

Strack GmbH

Volkmarsen, Germany
Phone: +49 5693 988 0
Email: info@phoenix-valvegroup.com
Website: www.phoenix-valvegroup.com

PAW SARL

Genay Cedex, France
Phone: +33 437 408 195
Email: commercial@phoenix-valvegroup.com
Website: www.phoenix-valvegroup.com

Daume Regelarmaturen GmbH

Volkmarsen, Germany
Phone: +49 5693 988 0
Email: info@phoenix-valvegroup.com
Website: www.phoenix-valvegroup.com

Solent & Pratt Phönix Ltd.

Volkmarsen, Germany
Phone: +49 5693 988 0
Email: info@phoenix-valvegroup.com
Website: www.phoenix-valvegroup.com



While this information is presented in good faith and believed to be accurate, Phönix Valve Group GmbH, does not guarantee satisfactory results from reliance on such information. Nothing contained herein is to be construed as a warranty or guarantee, expressed or implied, regarding the performance, merchantability, fitness or any other matter with respect to the products, nor as a recommendation to use any product or process in conflict with any patent. Phönix Valve Group GmbH, reserves the right, without notice, to alter or improve the designs or specifications of the products described herein.

© 2022 Phönix Valve Group. All rights reserved. Specifications are subject to change without notice. All trademarks are property of their respective owners

Printed in Germany
09/22-R0