



PHÖNIX

STRACK

DAUME
REGELARMATUREN

SIP Solent & Pratt
Phönix Ltd

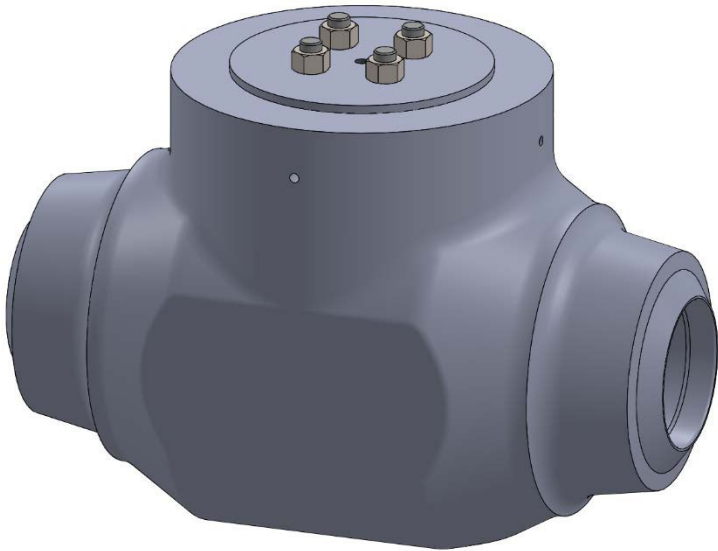

Swing Check Valve

Type S72

SDS 18, 20, 23

Phönix Valve Group
Am Stadtbruch 6
34471 Volkmarsen

Phone:
web:
eMail:

+49 5693 988 0
www.phoenix-valvegroup.com
info@phoenix-valvegroup.com



High Pressure Check Valve / S72

DN 50 - 300
SDS 18 / 20 / 23

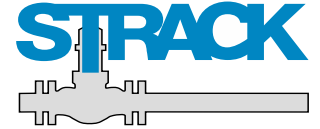

Design

- Pressure Seal
- Hinge pin inside
- Disc is separately assembled
- All forged materials without welding procedure

Dimensions

SDS 18	Size / DN	50	80	100	150	200	250	300
	L _{BW}	216	305	325	450	520	650	750
	H	110	145	172	230	295	370	410
	Weight (kg)	40	50	70	120	220	350	480

SDS 20	Size / DN	50	80	100	150	200	250	300
	L _{BW}	216	305	350	475	625	725	800
	H	110	145	172	230	295	370	425
	Weight (kg)	40	50	70	120	220	350	500

SDS 23	Size / DN	50	80	100	150	200	250	300
	L _{BW}	216	350	425	500	625	725	825
	H	110	145	172	230	310	390	450
	Weight (kg)	60	70	100	220	380	530	680

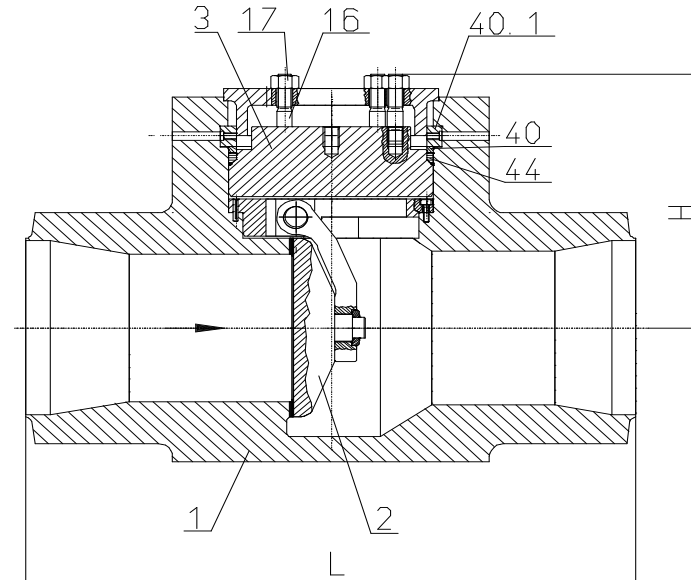

Drag coefficient / Flow coefficient

Size / DN	50	80	100	150	200	250	300
ζ_v [-]	on request						
k_v [m ³ /h]							

Other sizes on request

PHÖNIX reserves the right to change product design and specification without notice.

High Pressure Check Valve / S72

SDS 18 / 20 / 23 DN50 - DN300

Materials



Item	Part name	Heat resistant carbon steel		Low temperature steel **		Stainless steel **	
		Material *	DIN	Material *	DIN	Material *	DIN
1	Body	P250GH 16Mo3 13CrMo4-5 10CrMo9-10 X10CrMoVNb9-1	1.0460 1.5415 1.7335 1.7380 1.4903	P355NL1	1.0566	X 2CrNiMo17-12-2	1.4404
	Overlay	X15CrNiMn18-8	1.4370	X15CrNiMn18-8	1.4370	like body	
2	Disc	like body		like body		like body	
	Overlay	X15CrNiMn18-8	1.4370	X15CrNiMn18-8	1.4370	like body	
3	Pressure sealed cover	like body		like body		like body	
16	Stud bolt	21CrMoV5-7	1.7709	21CrMoV5-7	1.7709	A4 - 70	
17	Hexagonal nut	25CrMo4	1.7218	25CrMo4	1.7218	A4 - 70	
40	Thrust ring	like body		like body		like body	
40.1	Segment ring	like body		like body		like body	
44	Cover gasket	Stainless steel / graphite		Stainless steel / graphite		Stainless steel / graphite	

Special materials on request.

* Pressure-temperature-rating see appendix

** on request

Specification

Marking	EN19, AD-A4, CE
Face-to-face dimensions	
Butt weld ends	Manufacturer standard
Connections	
Butt weld ends	DIN EN 12627, DIN 3239
Testing standard	AD-2000, DIN 3230 section 3, DIN EN 12266

PHÖNIX reserves the right to change product design and specification without notice.

PHÖNIX • P +49 5693 988-0 • F +49 5693 988-178 • info@phoenix-valvegroup.com • https://phoenix-valvegroup.com

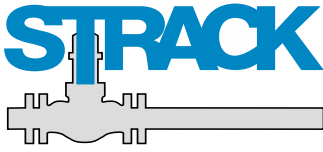

Pressure Temperature Rating acc. to DIN

°C	C22.8 1.0460					16Mo3 1.5415					WB 36 1.6368					14MoV6-3 1.7715					°C
	SDS10	SDS20	SDS32	SDS40	SDS50	SDS10	SDS20	SDS32	SDS40	SDS50	SDS10	SDS20	SDS32	SDS40	SDS50	SDS10	SDS20	SDS32	SDS40	SDS50	
20	120	230	330	450	570	137	262	365	513	650	202	386	538	756	958	144	276	384	540	684	20
100	114	218	313	427	540	127	243	338	475	602	188	361	502	706	894	135	259	361	508	643	100
150	104	199	285	389	492	118	225	314	441	559	186	357	497	698	885	132	254	353	497	629	150
200	91	175	251	342	433	108	207	288	405	513	181	347	483	679	860	128	246	342	481	609	200
250	82	156	224	306	388	98	189	262	369	467	176	337	468	659	834	116	222	308	434	549	250
300	72	138	198	270	342	86	166	230	324	410	170	327	454	639	809	109	210	292	410	520	300
350	62	120	172	234	296	82	156	218	306	388	164	315	438	616	780	104	199	276	389	492	350
380	59	113	162	221	280	80	154	214	301	381	162	310	431	607	768						380
390	56	107	153	209	264	79	151	210	295	374	159	305	425	598	757						390
400	53	101	145	198	251	77	147	205	288	365	157	302	420	590	748	100	192	268	376	477	400
410	51	98	140	191	242	76	146	204	286	363	156	298	415	583	739						410
420	49	94	135	184	233	76	145	202	284	360	154	294	410	576	730						420
430	44	84	120	164	207	75	144	201	283	358	144	276	384	540	684						430
440	38	73	104	142	180	75	144	200	281	356	131	251	349	491	622						440
450	33	63	91	124	157	74	143	198	279	353	118	225	314	441	559	97	187	260	365	463	450
460						74	142	197	277	351						97	186	259	365	462	460
470						73	141	196	275	349						97	186	259	364	461	470
480						69	132	183	257	326						97	185	258	363	459	480
490						56	108	150	211	267						96	185	257	362	458	490
500						45	86	119	167	212						93	178	247	347	440	500
510						36	68	95	133	169						82	156	218	306	388	510
520						28	54	76	106	135						72	137	191	268	340	520
530						23	43	60	85	107						62	120	166	234	296	530
540																54	104	145	203	258	540
550																48	91	127	178	226	550
560																41	79	110	155	196	560
°C	13CrMo4-4 1.7335					10CrMo9-10 1.7383					X10CrMoVNb91 1.4903					X10CrWMoVNb9-2 1.4901					°C
	SDS10	SDS20	SDS32	SDS40	SDS50	SDS10	SDS20	SDS32	SDS40	SDS50	SDS10	SDS20	SDS32	SDS40	SDS50	SDS10	SDS20	SDS32	SDS40	SDS50	
300	103	198	284	387	490																300
350	96	184	264	360	456	98	189	262	369	467											350
380	95	181	260	355	449	97	186	259	364	461											380
390	93	178	256	349	442	96	183	255	358	454											390
400	91	175	251	342	433	94	179	250	351	445											400
410	90	173	248	338	429	93	178	247	347	440	161	309	430	605	766						410
420	89	171	246	335	424	92	176	244	344	435	159	305	425	598	757						420
430	88	169	243	331	420	91	174	242	340	431	157	302	420	590	748						430
440	87	167	240	328	415	90	172	239	337	426	156	298	415	583	739						440
450	86	166	238	324	410	89	170	237	333	422	154	294	410	576	730	179	342	476	670	848	450
460	86	165	236	322	408	88	168	234	329	417	152	291	404	569	720	168	321	447	628	796	460
470	85	164	235	320	406	87	167	232	326	413	150	287	399	562	711	157	302	420	590	748	470
480	85	163	234	319	404	82	156	218	306	388	148	283	394	554	702	147	282	393	553	700	480
490	78	150	215	293	372	73	140	195	274	347	146	280	389	547	693	138	265	369	518	657	490
500	66	126	181	247	312	65	124	173	243	308	144	276	384	540	684	130	248	346	486	616	500
510	56	107	153	209	264	57	109	151	212	269	115	220	306	430	545	121	232	323	454	575	510
520	45	86	124	169	214	49	95	132	185	235	106	202	282	396	502	113	216	301	423	536	520
530	37	72	103	140	178	43	83	115	162	205	96	185	257	362	458	105	201	279	392	497	530
540	29	56	81	110	139	37	72	100	140	178	88	168	234	329	417	97	186	259	364	461	540
550	24	45	65	88	112	33	63	87	122	155	80	153	212	299	378	90	172	239	337	426	550
560	19	37	53	72	91	28	53	74	104	132	72	138	192	270	342	83	158	220	310	392	560
570	16	30	44	59	75	24	47	65	92	116	64	123	172	241	306	75	144	201	283	358	570
580						21	40	56	79	100	58	110	154	216	274	68	131	182	256	324	580
590											51	98	136	191	242	61	117	163	229	290	590
600											45	86	120	169	214	54	104	145	203	258	600
610																48	92	128	180	228	610
620																42	80	111	157	198	620

Contact us

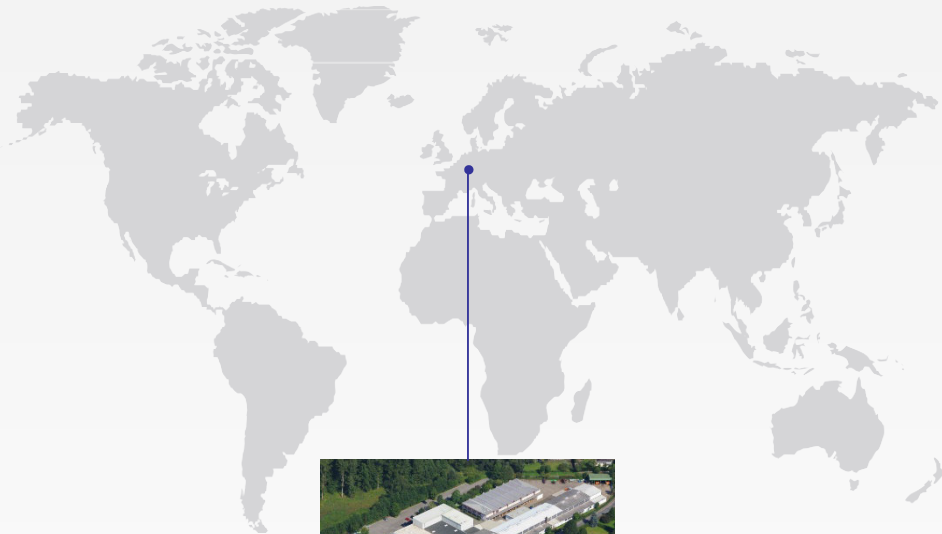

Volkmarsen, Germany

Sales and Operations

Phönix Valve Group GmbH

Volkmarsen, Germany
Phone: +49 5693 988 0
Email: info@phoenix-valvegroup.com
Website: www.phoenix-valvegroup.com

Phönix Armaturen Werke-Bregel GmbH

Volkmarsen, Germany
Phone: +49 5693 988 0
Email: info@phoenix-valvegroup.com
Website: www.phoenix-valvegroup.com

Strack GmbH

Volkmarsen, Germany
Phone: +49 5693 988 0
Email: info@phoenix-valvegroup.com
Website: www.phoenix-valvegroup.com

PAW SARL

Genay Cedex, France
Phone: +33 437 408 195
Email: commercial@phoenix-valvegroup.com
Website: www.phoenix-valvegroup.com

Daume Regelarmaturen GmbH

Volkmarsen, Germany
Phone: +49 5693 988 0
Email: info@phoenix-valvegroup.com
Website: www.phoenix-valvegroup.com

Solent & Pratt Phönix Ltd.

Volkmarsen, Germany
Phone: +49 5693 988 0
Email: info@phoenix-valvegroup.com
Website: www.phoenix-valvegroup.com



While this information is presented in good faith and believed to be accurate, Phönix Valve Group GmbH, does not guarantee satisfactory results from reliance on such information. Nothing contained herein is to be construed as a warranty or guarantee, expressed or implied, regarding the performance, merchantability, fitness or any other matter with respect to the products, nor as a recommendation to use any product or process in conflict with any patent. Phönix Valve Group GmbH, reserves the right, without notice, to alter or improve the designs or specifications of the products described herein.

© 2022 Phönix Valve Group. All rights reserved. Specifications are subject to change without notice. All trademarks are property of their respective owners

Printed in Germany
09/22-R0